



## SERIES 718 STEEL FILTER CHAMBERS

*Economical, in-line filter for:*

**HYDRAULIC / LUBE / CUTTING  
MINERAL AND FUEL OILS**



### FEATURES:

- **Carbon Steel Construction with Buna-N O-Ring**
- **Flow rate to 30 GPM**
- **Operating Pressure 75 PSI MAX.  
Operating Temperature 240°F MAX.**
- **Port size 1" NPT**  
Metric and flange available
- **Wall mount bracket included**  
Floor mounting legs optional
- **Single Cartridge**  
Accepts 7 x 18" Cartridges
- **Wall mount bracket included**

### 7" x 18" Industrial Cartridges (Bulletin M-206)

**Pleated Paper:** 1, 5, 10, 20, 30 micron for removal of from water and oil. Includes such applications as detergent, straight mineral and residual fuel oils; as well as water, glycol-water synthetics and oil-water emulsions.

**Cotton:** 10 micron for removal of particles from liquids such as hydraulic oil, fuel, quench and diesel engine lube oils; also machine tool coolants, solvents and other liquids.

**Fuller's Earth:** For removal of moisture, additives, and corrosive products from the oil. Ideal for use on fuel, hydraulic, insulating, and lubricating oils as well as jet fuels, quench, rolling and synthetic hydraulic oils.

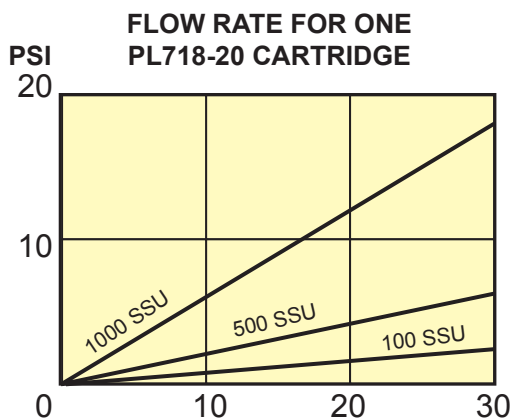



# SERIES 718 | STEEL FILTER CHAMBERS

2900 MacArthur Blvd. Northbrook, IL. USA 60062 [www.serfilco.com](http://www.serfilco.com) (800) 323 - 5431

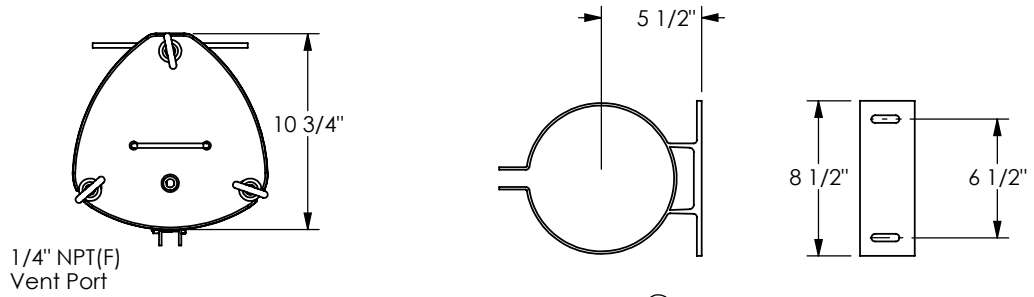

(B) 79-0938 Ring Bracket

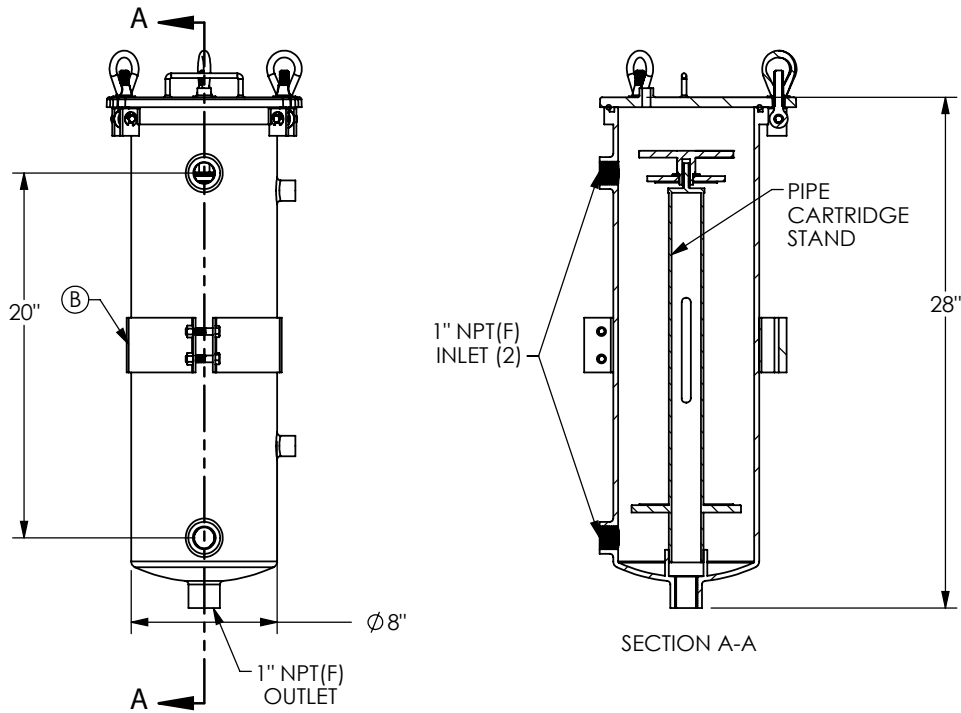

**TO ORDER, use Price Code Number**

MODEL NUMBER	OIL VOLUME GALS.	MAX. FLOW GPM	INLET & OUTLET NPT	SHIPPING WT. LBS	PRICE CODE NUMBER
S1(718)-1	5	30	1"	40	79-0940
ORDER FILTER CARTRIDGES SEPARATELY					
<b>OPTIONAL</b>					
COVER GASKET, VITON®					ADD-V
MOUNTING LEGS					79-0939