

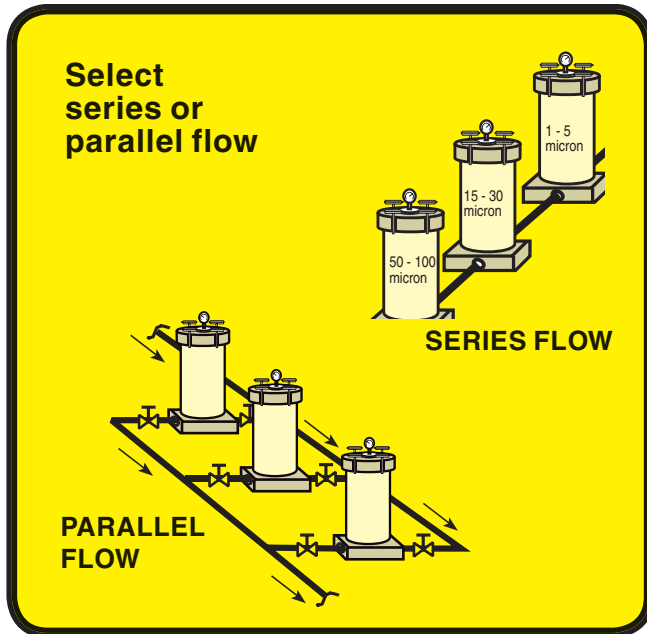

## CLARIFICATION & PURIFICATION CHAMBERS



### *Suitable for:*

### **SOLID / LIQUID SEPARATION, CARBON ADSORPTION and ION EXCHANGE RESIN**

- **Low, medium and high flow rates**
- **Recirculation or in-line**  
Parallel or series flow
- **Uninterrupted flow with low pressure drop**
- **Choice of media**  
Depth or pleated cartridges,  
cleanable sleeves,  
bags or discs,  
carbon or resin

SERFILCO recognizes the fact that not every liquid clarification requirement can be met with a pre-packaged filtration system. That is why we offer a range of standard, off-the-shelf filter chambers and a broad selection of filter media, such as bags, discs, depth and pleated cartridges, cleanable sleeves and carbon or resin purification to give you the flexibility you need to meet your clarification / purification requirements. By using different combinations of chambers and media, configured for recirculatory or in-line filtration, you can achieve the level of clarification / purification desired.

The selection of the most effective combination of elements for particle / liquid separation or purification depends upon a number of factors, including the size and nature of the particles to be removed. Determination of particle size is necessary to properly select the micron retention level of the filter media to be used. Through pilot testing or experimentation, this level can be determined. Often, the filtration efficiency of existing equipment can be improved by adding a filter chamber with coarse media upstream of the existing chamber to remove a large portion of the contaminants and thereby extend the life of the denser, more costly media in the downstream filter chamber.









The nature of the particles is also a key consideration. Are the particles "slimy", blinding off the media at the surface or will they remain porous and sand-like and develop a thick cake which, in turn, enhances the filtration / separation efficiency by removing finer and finer particles as the cake develops? The answers to these questions will lead to the choice of filter media.

The common perception is that bag filters continue to retain contaminant until they are filled to capacity and puffed up like a vacuum cleaner bag. This is generally not the reality of bag filtration. Instead, once the pores on the surface of the bag plug with fines, the bag needs to be cleaned for re-use. As a result, such a filtration system becomes very maintenance intensive.

On the other hand, systems which use depth type filter media require very little maintenance because depth type filters provide a high flow rate over more than 80% of their life before the flow rate is reduced to a level where cartridge maintenance is necessary.

The following pages identify some of the filter chambers and filter media available from SERFILCO. We have included a number of schematics to help you understand the variety of approaches that can be used to meet your clarification / purification needs.

## Choose the style of chamber . . .

<p><b>SERIES 'L'</b></p>  <p>Made of PVC, CPVC, polypropylene or 100% pure PVDF. ¾" or 1" port sizes.</p> <p>Flow rates to 34 GPM.</p>	<p><b>SERIES 'S'</b></p>  <p>Made of PVC, CPVC, polypropylene or 100% pure PVDF. 1" or 1¼" port sizes.</p> <p>Flow rates to 68 GPM.</p>	<p><b>SERIES 'G' &amp; 'GC'</b></p>  <p>Made of PVC, CPVC, polypropylene or 100% pure PVDF. 1½" port size.</p> <p>Flow rates to 110 GPM.</p>	<p><b>SERIES 'GH-HP'</b></p>  <p>Made of PVC, CPVC, polypropylene or 100% pure PVDF. 1½", 2 or 3" port sizes.</p> <p>Flow rates to 275 GPM.</p>
<p><b>SERIES 'FRP'</b></p>  <p>Made of filament-wound fiberglass and epoxy with integral domed bottom. 2" ports.</p> <p>Flow rates to 320 GPM.</p>	<p><b>SERIES 'WT'</b></p>  <p>Made of PVC. 2" ports.</p> <p>Flow rates to 140 GPM.</p>	<p><b>SERIES 'HF'</b></p>  <p>Made of PVC with polypropylene and CPVC internals. 3" ports.</p> <p>Flow rates to 400 GPM.</p>	<p><b>SERIES 'DR'</b></p>  <p>Made of welded steel with rubber lining. 3" ports.</p> <p>Flow rates to 315 GPM.</p>

## and filter media . . .



**DEPTH**



**PLEATED  
w/222 'O'-RING**



**SLEEVES**



**POWDERED  
CARBON**



**GRANULAR  
CARBON**



**CANISTER  
for CARBON  
or RESIN**



**BAGS**



**DISCS**

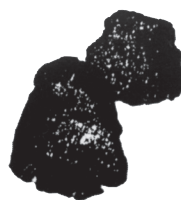

**BULK CARBON  
or RESIN**

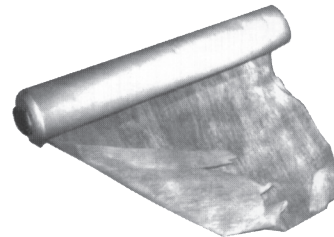

**PAPER  
or FABRIC**

# and customize for optimum results!

**GRAVITY PLUS FINAL TRAP PRESSURE FILTRATION** for recirculation handles heavy sludge loads and results in exceptional clarity.

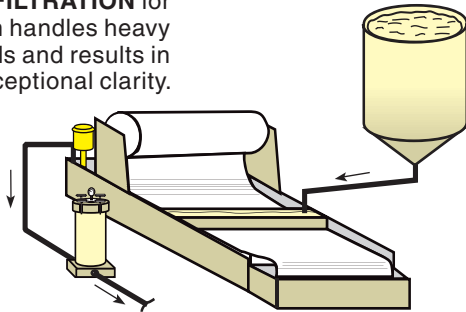

**SERIES FLOW** with step-down particle retention increases solids holding capacity, minimizes service required, achieves desired clarification.

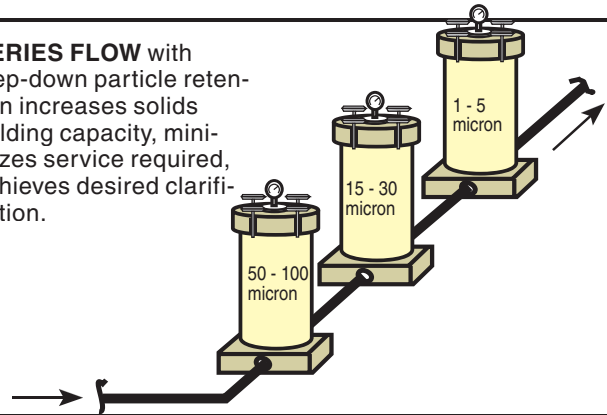

**SIMPLE DUPLEX SYSTEM** with parallel or alternate flow.

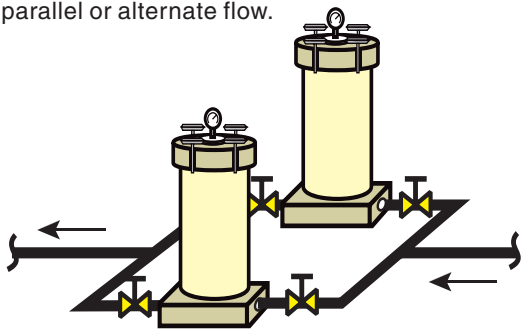

**RECIRCULATORY FILTRATION** with bypass carbon or resin for purification.

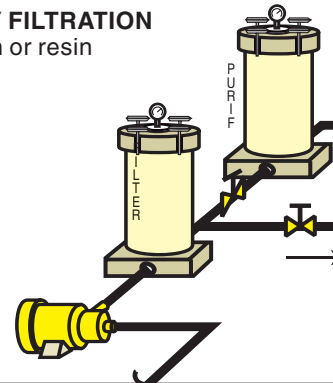

**PARALLEL FLOW** uninterrupted flow with lowest pressure drop to meet any flow capacity.

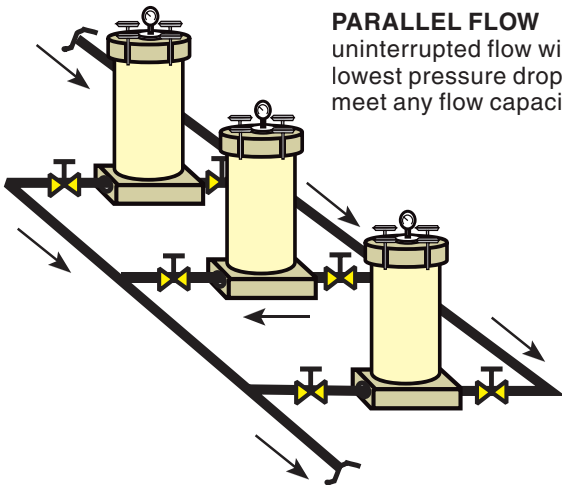

**MULTI-FUNCTION** Trap filtration for solids removal, carbon adsorption and resin exchange. Includes booster pump in-line.

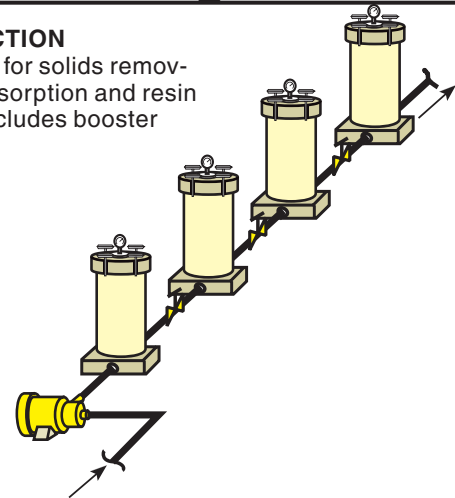

**COMBINATION OF PARALLEL AND SERIES** to meet higher demands of any one functional requirement.

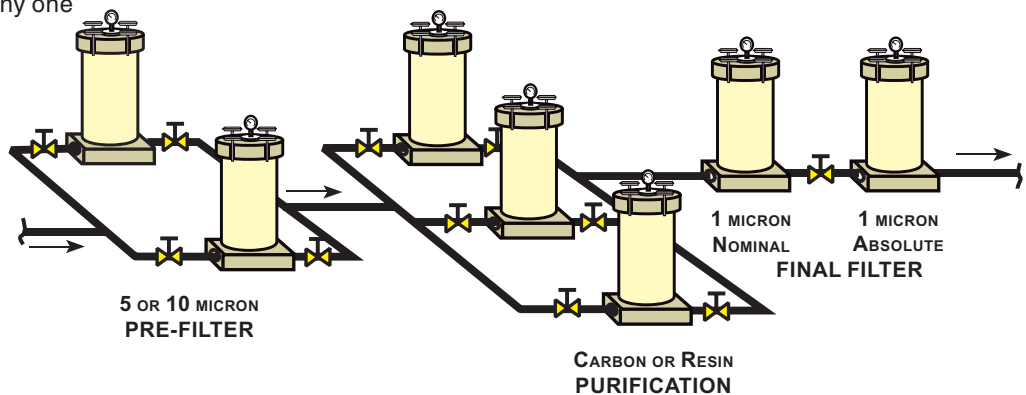

# SERFILCO also offers:

## FILTER PRESSES

For dewatering hazardous wastes and municipal sludges, reclamation of solids, clarification and recovery of chemicals and costly solutions. Recessed, gasketed polypropylene plates with air operated hydraulic closure. Standard models to 50 cu. ft. Larger sizes available upon request.

## AUTOMATIC FILTRATION SYSTEMS

Fully automatic backwash systems for filtration and polishing of many liquids including cleaners, plating solutions or treated waste streams. Systems utilize permanent media. Flow rates to 500 GPM.

## AUTOMATIC INDEXING FABRIC FILTERS

Filters provide efficient solids-liquid separation. Automatic indexing of filter media permits uninterrupted flow of solution from process to filter. Recommended for machine oils, tool coolants, treated waste solutions, industrial waste water, cooling tower water, fume scrubbers, water wall paint overspray, and other industrial process applications. 1.5 to 113 sq. ft. filter area.

## CARTRIDGE / BAG FILTRATION SYSTEMS

Liquid / solid separation systems employing gravity flow filter bags plus a final trap filter to provide recirculation filtration for PC board scrubber / deburring machines; bottle washers, plastic recycling and many other waste treat applications.

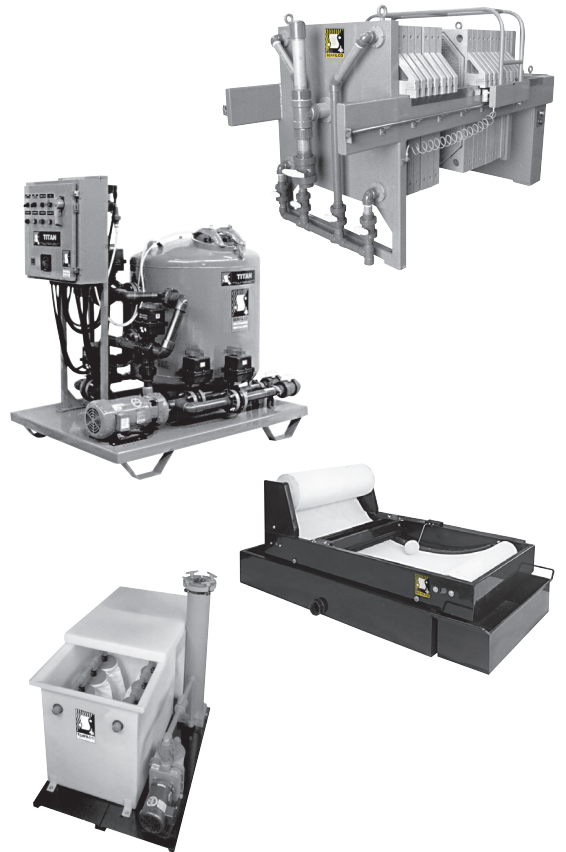

Customize your own liquid filtration system with SERFILCO off-the-shelf components!

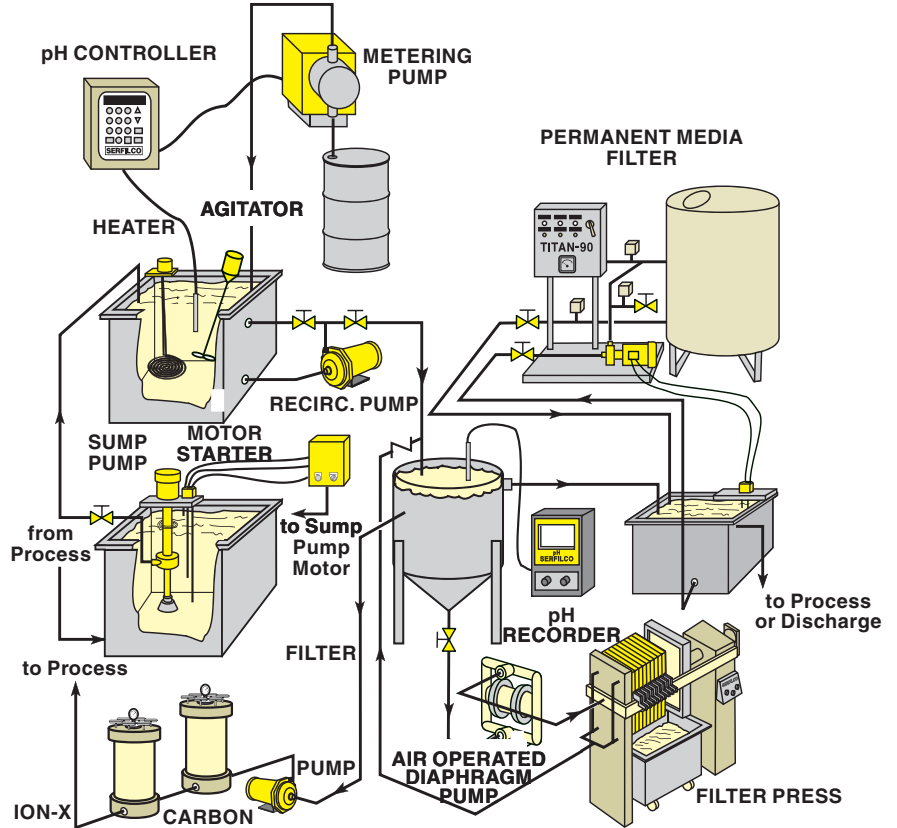

**SERFILCO**

2900 MacArthur Blvd. 847-559-1777  
 Northbrook, IL 60062-2005 U.S.A. 800-323-5431  
 e-mail: sales@serfilco.com FAX: 847-559-1995  
 www.serfilco.com