

# CARBON PURIFICATION SYSTEMS



MODELS:	PRICE CODE NOS.
R5(528P)CC 3/4V 7MPGR-C.75-G5	S-0359
R5(528P)CCxCL60(2) 3/4V 7 MPGR-C.75-G5	S-0360
R10(528P)CC 3/4V 7MPGR-C.75-G5	S-0361
R10(528PVC)CCxCL120(4) 3/4V 7MPGR-C.75-G5	S-0362

Refer to Product Bulletin R-103.

## SAFETY PRECAUTIONS

1. Read operating instructions and instructions supplied with chemicals to be used.
2. Refer to a chemical resistance data chart for compatibility of materials with solution to be used.
3. Note temperature and pressure limitations.
4. Personnel should always wear suitable protective clothing: face mask or goggles, apron and gloves.
5. All piping must be supported and aligned independently of the chamber.
6. Always close valves slowly to avoid hydraulic shock.
7. Ensure that all fittings and connections are properly tightened.

## BEFORE CHANGING APPLICATION OR PERFORMING MAINTENANCE

1. Wear protective clothing as described in item 4 of Safety Precautions above.
2. Flush pump thoroughly with a neutralizing solution to prevent possible harm to personnel.
3. Verify compatibility of materials as stated in item 2 of Safety Precautions above.

## INSTALLATION

These carbon chambers are constructed of rubber lined steel. They contain either 5 or 10 PVC inner canisters, each containing 10 lbs. of granular activated carbon with a 3 micron polypropylene fiber trap filter to prevent migration of carbon into the system. The flanged inlet is at the side of the vessel and the flanged outlet is at the bottom.

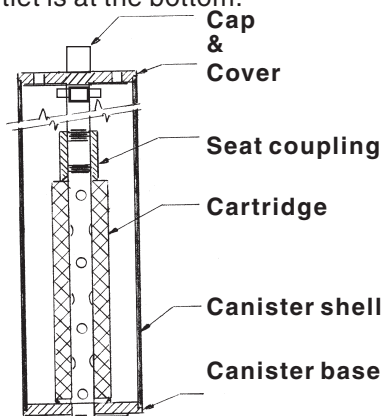

Carbon canister

The quality of solution purification using granular activated carbon is dependent upon several factors such as: type of solution, temperature, type and degree of impurities in solution, type of carbon, depth of carbon bed

and solution contact time (flow rate). Controllable factors are flow rate and type of carbon. A longer contact time between solution and carbon requires a lower flow rate. System performance should be established to determine optimum adsorbancy vs. flow rate relationships.

1. Install with proper size pipe of compatible material. It is recommended that flow control valves be installed on chamber inlet and outlet with a drain at the low point of either.
2. Check tightness of nuts on swing bolts holding down the cover. They should be down tight to seal the cover to the vessel. Lined vessels have a hard lining which requires high bolt pressures for proper sealing. Be sure to back off davit handwheel when tightening swing bolts.

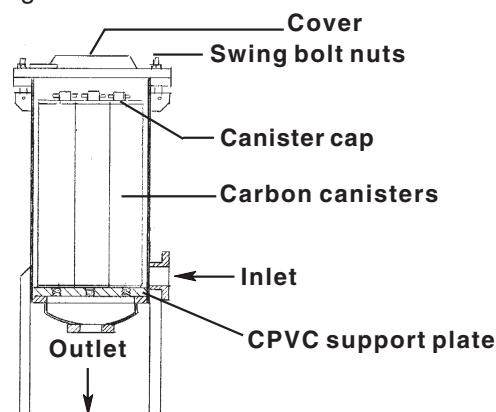

3. Install all hoses (disconnected for shipping) and tighten hose clamps. Siphon breakers in the suction line to the pump and filter discharge to the tank should be installed as a further precautionary measure to limit and minimize the amount of liquid lost by back siphoning. An effective siphon breaker is a small hole drilled in the suction & discharge lines approximately 2" to 4" below the normal solution level.

## START-UP

1. Flush carbon with volume of water or process solution until discharge runs clear. A drain valve on the outlet line is convenient for sampling discharge.
2. Adjust inlet flow control valve. Lower flow rates provide greater purification per gallon output.
3. Prior to exiting each canister, the solution passes through a trap filter cartridge. Unless specified otherwise, these cartridges are 3 micron, polypropylene.
4. Carbon requires replacement when it no longer has

its adsorbancy property. Trap filters require replacement when the required **minimum** flow rate cannot be maintained.

## SERVICE

### To Replace Carbon:

1. Shut-off the power supply to the pump and shut the discharge valve from the pump. If there is a prefilter, shut the valve between the prefilter and carbon chamber. Then drain the carbon chamber of all solution.
2. Remove vessel cover by loosening hex nuts on swing bolt and lifting cover off vessel, exposing the re-usable canisters.
3. To remove canister from the chamber, lift canister by grasping shell or lift by tee handle below canister cover.
4. Place canister on a table or suitable support where carbon can be conveniently dumped. Remove top cover by removing cap at end. Canister should be in a horizontal position so that opposite end of canister can be lifted to dump the carbon. Bottom of canister can be lifted out with the trap filter and piping.
5. To replace the trap filter, unscrew the coupling at the top end of the cartridge which then can be removed and replaced.
6. After replacing the trap cartridge, the canister can now be refilled with clean carbon and replaced into the chamber. Wrap threads on pipe extension with TFE tape for ease of disassembly. Vessel cover can be installed and tightened per step #2 under Installation.

## PURIFICATION TIPS

1. **By-pass Purification:** Carbon chamber is installed on filter discharge with control valve on chamber inlet. Flow through carbon is adjusted to approximately 1 to 3 GPM per each 10 lb. canister. Continuous recirculation by this method should eliminate or significantly postpone batch treatment with powdered carbon.
2. **Full flow Purification:** Valve "A" is closed, and valve "B" is opened to provide suitable flow. A low flow rate will provide optimum adsorbancy during transfer.

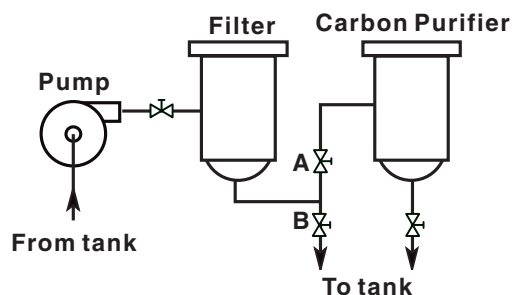

3. A regular analysis of carbon chamber discharge will establish ideal flow rate and disclose when carbon replacement is necessary.
4. A pressure gauge on carbon chamber inlet will permit valve adjustment for repeatedly obtaining identical flow rate.
5. Replacement carbon and trap filters should be ordered and placed in stock for immediate availability. Replacement 3 micron trap filter

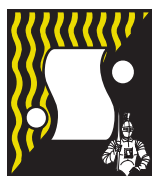

**SERFILCO<sup>®</sup>, LTD.**

2900 MacArthur Blvd. 847-509-2900  
Northbrook, IL 60062-2005 U.S.A. 800-323-5431  
e-mail: sales@serfilco.com FAX: 847-559-1995  
www.serfilco.com