



# DRUM/BARREL PUMPS EF SERIES

## Sealless, Best Value

This pump provides an economical and lightweight choice for light duty transfer. Ideal replacement for hand pumps.

- Polypropylene (PP), pure PP/PVDF, 316SS tubes
- Interchangeable with motors
- Dual speed adjustable motors
- Integral strainer
- Built-in hose, cord clips (EFP/EFV only)



### Applications:

Light acids and bases, solvents<sup>1</sup>, plating solutions, sodium hypochlorite, cleaners, coolants, diesel exhaust fluid (DEF)/AdBlue



Pat. US D658,273 S; Pat. US D657,849 S; Pat. ZL 201130042121.X; Pat. ZL 201130042107.X; OHIM Pat. 001839002-0002; OHIM Pat.001839002-0001

## CONSTRUCTION SPECIFICATIONS

Pump Model	Construction Materials		Tube Dia. in (cm)	Discharge Size & Type	Hose Size in (cm)	Max. Temp.*		Min. Temp.		Tube Lengths in (cm)
	Outer Tube	Internals				°F	°C	°F	°C	
EFP	PP	316SS, FKM, PTFE, PP	1-1/4 (3.2)	3/4" Hose Barb	3/4 (1.91)	150	66	0	-18	16 (41) 27 (69)
EFV	Pure PP/Pure PVDF	Alloy 625, FKM, PTFE, ETFE, PP	1-5/16 (3.3)			160	71	0	-18	40 (102) 48 (122)
EFS	316 Stainless Steel	316SS, FKM, PTFE, ETFE	1-1/4 (3.2)			212	100	0	-18	54 (137)**

\*EFV-54 Maximum Temperature = 150°F (66°C)

\*\*54 inch (137 cm) tube length available only in EFP and EFV

<sup>1</sup>When pumping flammables or combustibles, use explosion proof electric or air drive motors on stainless steel tubes with static protection kit.

Note: ATEX versions of some pump models are available. Please see EF Series ATEX flyer or contact Finish Thompson.

## PERFORMANCE DATA

Maximum Flow <sup>1</sup>			Maximum Head <sup>1</sup>			Max. Specific Gravity <sup>2</sup>	Maximum Viscosity		
Elec. gpm (lpm)	Air gpm (lpm)	12V gpm (lpm)	Elec. ft (m)	Air ft (m)	12V ft (m)		Elec.	Air	12V
17 (64.4)	15 (56.8)	14 (53.0)	20 (6.1)	17 (5.2)	13 (4.0)	1.6	300 cP	300 cP	100 cP

<sup>1</sup>All testing performed with water at 68°F (20°C). Actual performance can vary by +/- 10%. Actual performance will decrease with increased fluid viscosity and specific gravity.

<sup>2</sup>Max. specific gravity is dependent on fluid viscosity. Refer to Specific Gravity Maximums table & curve below.

## VISCOSITY DATA

Electric/Air Motor				12V Motor		
Viscosity (cP)	100	200	300	Viscosity (cP)	50	100
Max Flow gpm (lpm)	7 (26)	5 (19)	4 (14)	Max Flow gpm (lpm)	7 (26)	3 (11)
Max Head ft (m)	16 (5)	16 (5)	16 (5)	Max Head ft (m)	11 (3)	14 (4)

Note: Viscosity data is based on motors operating at high speed.

Use the handy online Pump Selector at [www.finishthompson.com](http://www.finishthompson.com) for help choosing a pump.



Maximum Performance Limits			
High Speed Motor Setting			
If specific gravity is:	viscosity cannot exceed:		
	S1, S2, S3, S4	S6	
1.0	300 cP	100 cP	
1.1	300 cP	50 cP	
1.2	125 cP	1 cP	
1.6	1 cP	-	
Low Speed Motor Setting			
If specific gravity is:	viscosity cannot exceed:		
	S1, S2, S3	S6	
1.0	100 cP	25 cP	
1.2	75 cP	25 cP	
1.6	1 cP	25 cP	

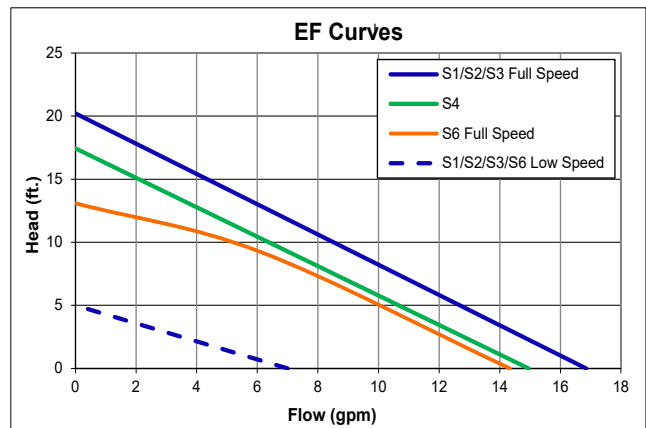

# DRUM/BARREL PUMPS

## MOTOR DATA



ODP (S1, S2, S3, S6\*)



Air (S4)

Model	Description	Certification	Electrical Requirements	Input	Output	RPM	Maximum Viscosity cP
				W	W		

### ODP (Open Drip Proof), Splashproof, IP24 Motors

S1	Ergonomic, lightweight design with downdraft cooling. Continuous duty, dual speed, double insulated. 12 ft. (3.5 m) cord with plug and manual reset circuit breaker included.	QPS	115VAC/60 Hz	230	110	8,000/14,000	300
S2		CE	230VAC/50-60 Hz	230	110	8,000/14,000	300
S3 <sup>†</sup>		CE	115V/50-60 Hz	230	110	8,000/14,000	300
S6	Ergonomic, lightweight cordless design. Built-in rechargeable lithium ion battery pack. Dual speed. Dual cooling fans w/ overload protection. Charging jack w/ flip cover. Patent pending.	CE	12V (10.8V w/ work load)	150	100	8,000/12,000	100

<sup>†</sup>S3 motor is built to meet UK 115V requirements and does not include plug

### Air Motors<sup>\*</sup>

S4 <sup>**</sup>	Lightweight. Operates from customer-supplied compressed air source. Variable speed. Muffler and control valve.	CE	40 psi @ 27 cfm	-	400	300-11,000	300
------------------	--	----	-----------------	---	-----	------------	-----

<sup>\*</sup>An air motor is a non-electrical device which means the possibility of explosion from igniting flammables or combustibles is reduced. Air motor performance will depend upon user's compressor and system setup.

<sup>\*\*</sup>Motor suitable for hazardous areas that do not require independent certification.

Note: ATEX versions of some motors are available. Please see EF Series ATEX flyer or contact Finish Thompson.

## DIMENSIONS

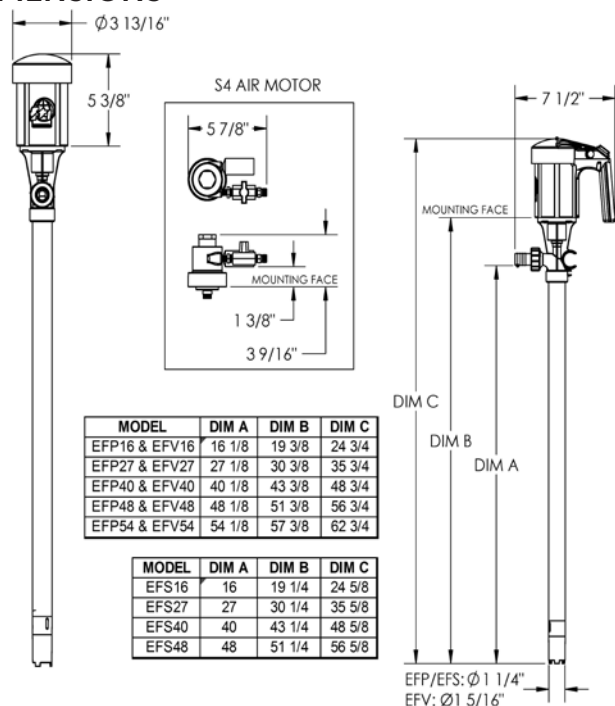

## ACCESSORIES

### Wall Hanger

Stores pump & charger upright on the wall



### Charger

Standard or car charger

### Static Protection Kit

4 ft. (122 cm) synthetic rubber cross-linked PE grounded hose with brass fittings with 3/4" MNPT, ground wire, and clamps



### Discharge Hose

Reinforced PVC, EPDM

### Dispensing Nozzles

Polypro/316SS, Stainless steel/FKM



### Bung Adapters

Stainless Steel, Polypropylene