



FINISH THOMPSON INC.

EF SERIES

EFS ATEX VERSION

(INCLUDES OPTIONAL S4A MOTOR & SPK)

OPERATION & PARTS MANUAL



Introduction

This manual pertains to the EF Series, specifically the ATEX version of the EFS stainless steel drum pump. Finish Thompson Inc. thanks you for choosing our products. We believe the use of our products will be fully satisfactory. When properly installed and operated, your Finish Thompson motor and pump will provide long, trouble-free service; therefore, please read this manual carefully before carrying out any operations on the pump/motor unit. Any use other than that described herein is considered incorrect; and, consequently, Finish Thompson Inc. shall not be held responsible for any damages to people or property. In case of doubt or enquiries, please reply to our Technical Service department directly at the following address:

Finish Thompson, Inc.
921 Greengarden Rd.
Erie, PA 16501 U.S.A.
Tel. 1-814-455-4478; Fax 1-814-455-8518
www.finishthompson.com; fti@finishthompson.com

Index

Introduction	2
Warranty, General Terms & Conditions	3
Safety	4-5
Pump Specifications	5
ATEX Specifications	6
EFS Installation	7
Static Protection Kit Assembly	7-8
Operation	8
Maintenance	
Disassembly	8-9
Inspection	9
Reassembly	9-10
Exploded Views	11
Pump Tube Spare Parts List	12
S4A Spare Parts List & View	13
ATEX Certificates	14
CE Certificates of Conformity	15-17

Technical Service Hotline: 1-800-888-3743 or email techservice@finishthompson.com

Warranty, General Terms & Conditions

1. The following terms and conditions apply to the sale of machinery, components and related services and products, of Finish Thompson Inc. (hereinafter “the products”)
2. Finish Thompson Inc. (the manufacturer) warrants only that:
 - a) its products are free of defects in material, design and workmanship at the time of original purchase;
 - b) its products will function in accordance with Finish Thompson Inc. operation manuals; Finish Thompson Inc. does not guarantee that the product will meet the precise needs of the Customer, except for those purposes set out in any invitation to render documents or other documents specifically made available to Finish Thompson Inc. before entering into this agreement;
 - c) high quality materials are used in the construction of the pumps and that machining and assembly are carried out to the highest standards. Except as expressly stated above, Finish Thompson Inc. makes no warranties, express or implied, concerning the products, including all warranties of fitness for a particular purpose.

This warranty shall not be applicable in circumstances other than defects in material, design, and workmanship. In particular warranty shall not cover the following:

- d) Periodic checks, maintenance, repair and replacement of parts due to normal wear and tear;
- e) Damage to the product resulting from:
 - i. Tampering with, abuse or misuse, including but not limited to failure to use the product for its normal purposes as stated at the time of purchase or in accordance with Finish Thompson, Inc. instructions for use and maintenance of the product, or the installation or improper ventilation or use of the product in a manner inconsistent with the technical or safety standard in force;
 - ii. Repairs performed by non-authorized service workshop, or opening of the unit by non-authorized personnel, or use of non genuine Finish Thompson Inc. parts;
 - iii. Accidents, force majeure or any cause beyond the control of Finish Thompson Inc., including but not limited to lightning, water, fire, earthquake, and public disturbances, etc.
3. The warranty shall cover the replacement or repair of any part, which is documented to be faulty due to construction or assembling, with new or repaired parts free of charge delivered by Finish Thompson, Inc. Parts subjected to normal wear and tear shall not be covered by the warranty. Finish Thompson, Inc. shall decide as to whether the defective or faulty part shall be replaced or repaired. Transportation charges are prepaid to Finish Thompson.
4. The warranty of the products shall be valid for a period of **12 months** from the date of delivery, under the condition that notice of the alleged defect to the products or parts thereof be given to Finish Thompson, Inc. within the term of 8 days from the discovery.
5. Repair or replacement under the terms of this warranty shall not give a right to an extension to, or a new commencement of, the period of warranty. Repair or replacement under the terms of this warranty may be fulfilled with functionally equivalent reconditioned units. Finish Thompson Inc. qualified personnel shall be solely entitled to carry out repair or replacement of faulty parts after careful examination of the motor. Faulty parts or components when replaced by Finish Thompson Inc. will become the property of Finish Thompson Inc. If this warranty does not apply, the purchaser shall bear all cost for labor, material and transportation.
6. Finish Thompson Inc. will not be liable on any claim, whether in contract, tort, or otherwise, for any indirect, special, incidental, or consequential damages, caused to the customer or to third parties, including loss of profits, process down time, transportation costs, costs associated with replacement or substitution products, labor costs, installation or removal costs. In any and all events, manufacturer’s liability shall not exceed the purchase price of the product and/or accessories.
7. **Return Policy.** Should you have any problems with this product, please contact the distributor in your area. The distributor will determine if a return to the factory is necessary and will contact the factory for a Return Authorization Number. Otherwise, contact our Technical Service Hotline (1-800-888-3743) or e-mail techservice@finishthompson.com if you have any questions regarding product operation or repair.

Warranty Registration

Thank you for your purchase of this quality Finish Thompson product. Be sure to take a minute to register your pump at Finishthompson.com/warranty. Simply provide the model number, serial number and a few other pieces of information.

Safety

1. Introduction

This manual contains all the information needed for the correct installation, use and maintenance of your new Finish Thompson pump. It should be read and understood by all the personnel involved in installation, operating and servicing of the pump before it is started.

2. Operator Qualification and Training

The personnel in charge of the installation, the operation, and the maintenance of the pump must be qualified and able to perform the operations described in this manual. Finish Thompson, Inc. shall not be held responsible for the training level of personnel and for the fact that they are not fully aware of the contents of this manual.

3. Safety Instructions

FOR YOUR OWN SAFETY

 **BEFORE** using or servicing your pump, please make sure to wear the proper clothing, eye protection and follow standard safety procedures when handling corrosive or personally harmful materials.

GENERAL DANGER

 **ALWAYS** use a Model EFS ATEX pump tube with a Model S4A air motor. A grounded discharge hose and grounding wire are also required and must be connected according to these instructions under the section below titled “Static Protection Kit Assembly”. Finish Thompson Inc. recommends using their “Static Protection Kit with grounded discharge Hose” P/N 107429. Similar to the Finish Thompson “Static Protection Kit with grounded discharge Hose”, any customer supplied grounded discharge hose must ensure a fluid velocity less than 1m/s (3.2ft./s.) and compliance with EN 13463-1 and CLC/TR 50404.

ALWAYS use and store the pump and motor in an upright position.

NEVER use in pressurized containers.

ALWAYS use a chemically compatible hose rated for the temperature of the product being pumped.

ALWAYS select the proper o-ring material. Improper material selection could lead to swelling and be a possible source of leaks. This is the responsibility of the end user.

ALWAYS check the pump for leaks on a regular basis. If leaks are noticed, the pump must be repaired or replaced immediately.

ALWAYS clean the pump on a regular basis to avoid any dust buildup greater than 5mm deep.

ALWAYS check compatibility and temperature range of pump with liquids used. A Chemical Resistance and Material Selection Guide can be downloaded from our website at www.finishthompson.com.

NEVER run dry.

NEVER use with liquids containing solids that can damage the internals (i.e. metal chips) without optional strainer.

ALWAYS flush unit with water after each use.

ALWAYS store unit upright, i.e. motor above pump, and away from corrosive liquids and vapors.

ALWAYS check bearings, bushings, & sleeves for signs of grinding, abnormal noise, overheating, or other signs of premature failure on a daily basis. Bearings, bushings, & sleeves should be replaced at the first sign of failure. Ensure the impeller spins freely by hand and does not bind.

ALWAYS check the pump after an impact or drop. Ensure the tube and shaft are not bent and the impeller spins freely by hand without binding. Excessive running vibration may indicate a bent tube or shaft. Replace any bent or damaged components prior to operation.

ALWAYS check that all hardware is tightly fastened to ensure the motor is securely attached to the pump.

ALWAYS when using an air motor, use an automatic airline lubricator, moisture trap, and filter in the airline before the motor (use SAE#10 oil in the lubricator). Adjust lubricator to feed one drop of oil per minute of continuous run time. Do not exceed 40 psi (2.8 bar) on S4A. Maximum air consumption: S4A = 27 cfm (12.5 lps).

 **DANGER: POWER SUPPLY** Refer to instructions in this manual.

4. Noise Level

78 db at a distance of 3 feet (approximately 1 meter).

5. Modifications and Spare Parts

Any changes concerning the service of the pump as originally purchased can be executed only after written approval from Finish Thompson Inc. It is recommended to use only genuine Finish Thompson Inc. spare parts and approved accessories. The use of non-original spare parts or non-approved accessories will void warranty and removes any responsibility on the manufacturer's behalf for any damage caused to people or things.

6. Cleaning

It is highly recommended to flush pumps with clean water or some other neutralizing fluid compatible with pump materials when done pumping or when switching chemicals.

PUMP SPECIFICATIONS	
Outer Tube Diameter	1-1/4" (3.2 cm)
Discharge Spout	3/4" Barb
Discharge Thread	Optional
Max. Specific Gravity	1.6
Max. Viscosity	50 cP (when used with S4A and SPK)
Min./ Max. Fluid Temperature	0° F Min. to 212° F Max.
	(-18° C Min. to 100° C Max.)
Wetted Materials	316 SS, FKM, PTFE, ETFE, PFA, (optional Ekonol, EPDM, Perlast)

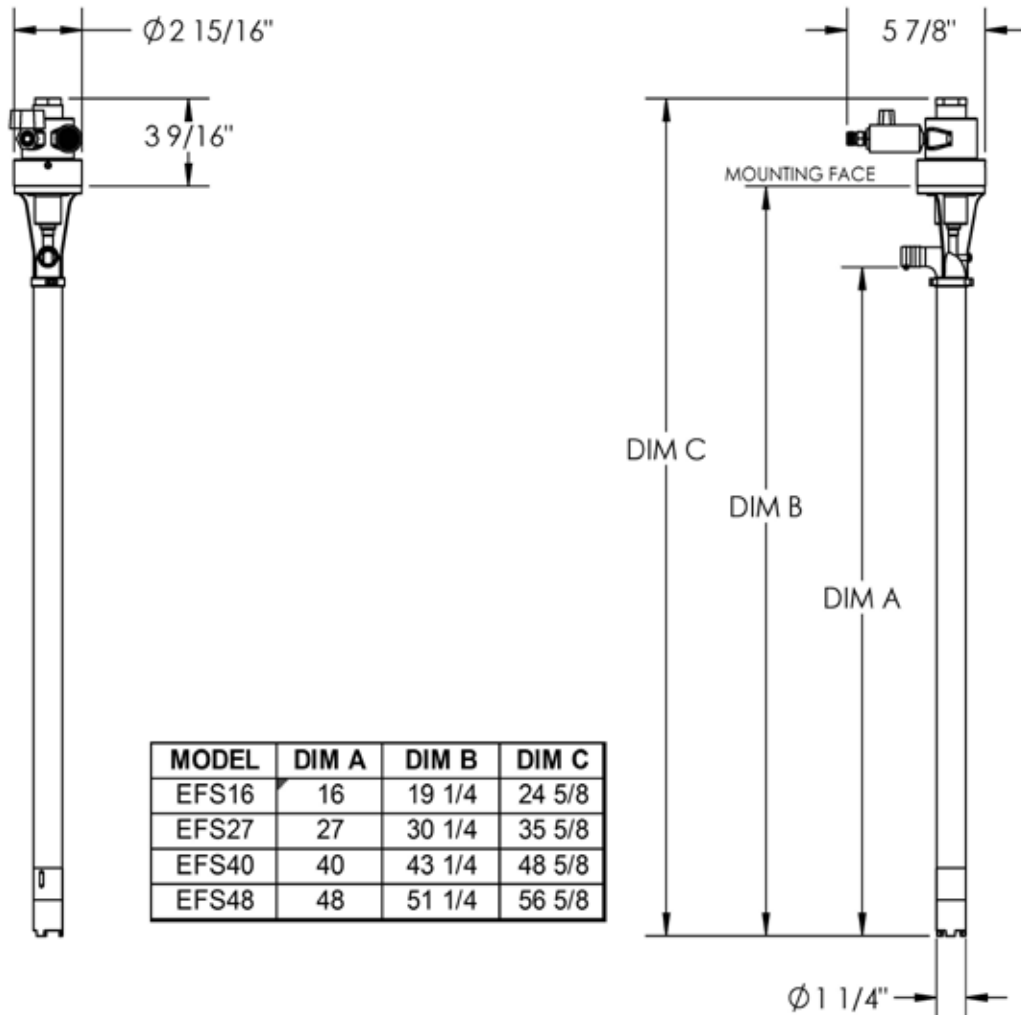

ATEX COMPLIANCE

The FTI EFS ATEX drum pump has been designed for use in hazardous environments. It meets the requirements set forth by EC directive 94/9/EC. This pump is designed to operate in zone 0 where explosive atmospheres are present. All three components (EFS ATEX pump, S4A motor, and grounded hose / ground cables) must be properly installed.

TEMPERATURE CLASSIFICATION

Below is a chart showing the temperature class that the pump falls in when used in locations where the ambient air temperature is no greater than 104°F (40°C). The EFS, when used in hazardous locations, should only be used on products that allow for safe operation within these classes.

Temperature Class	Maximum Allowable Surface Temperature
T3	200° C

ATEX MOTOR INFORMATION



This symbol appears on labels of motors that are designed for use in hazardous atmospheres.

These motors comply with the applicable standards and specifications and meet the requirements of the guidelines of the EC directive 94/9/EC (ATEX 100a). They are intended to be used in zones 1 and 2 where explosive atmospheres are likely to occur.

Complete the following checklist prior to starting installation in a hazardous area. All actions must be completed in accordance with ATEX 100a.

Checklist for installation in hazardous areas:

- Read motor label to check that motor has been designed for use in a hazardous application:
- Hazardous Zone
- Hazardous category
- Equipment group
- Temperature class
- Maximum surface temperatures
- Check the site environment for potentially explosive oils, acids, gases, vapors or radiation
- Check the site to make sure that the motor will be adequately ventilated and that there is no external heat input. The cooling air may not exceed 104°F/40°C.
- Check that the motor is not damaged.
- Maximum motor surface temperature should not exceed 392°F/200°C based on ATEX temperature class T3 ambient range +1C° to + 40°C (34°F / 104°F).

Installation, Assembly & Maintenance Instructions

EFS Motor Installation

Installation

1. Remove the drum pump and motor from its packaging and inspect for shipping damage.
2. Verify that the “Diffuser Cover” (item 19) is on tight (it has left hand threads).
3. Spin the pump coupling to verify there is no binding.
4. Place the motor upside down on a tabletop surface with the coupling facing upwards and place the yellow coupling insert onto the motor’s coupling. *See figures 1 & 2.*
5. Firmly press the pump tube onto the motor until it is fully seated. A slight twist may be necessary for the coupling splines to line up properly.
6. Align the 4 bolt holes in the pump to the 4 holes in the motor, and fasten with 4 Philips screws (item 8) and 4 Lock washers (item 9).
7. Tighten using a # 2 Phillips head screwdriver.
8. Connect a grounded hose and grounding wires per diagram located below. FTI recommends using Static Protection Kit P/N: 107429.



Figure 1



Figure 2

NOTE: When pumping flammable or combustible materials, DO NOT operate the pump unless a grounded hose and ground wires are properly connected as shown below; otherwise, the pump/motor will not comply with ATEX requirements.

Static Protection Kit Assembly

Hose attachment to pump:

1. Place the stainless steel hose clamp onto the short section of the grounded hose.
2. Slide the short section of the grounded hose assembly over the pump tubes discharge spout. Tighten the clamp.
3. Attach the ground wire assembly to the pump tube using the #8 ring terminal and supplied 8-32 x 1/4” brass screw and brass lock washer.
4. Attach the ground wire assembly to the motor (see instructions below).
5. Check electrical continuity between the clamp on the end of the ground wire assembly and the end of the grounded hose. The electrical resistance must be one (1) Ohm or less. If it is greater than one (1) Ohm, re- check all connections.

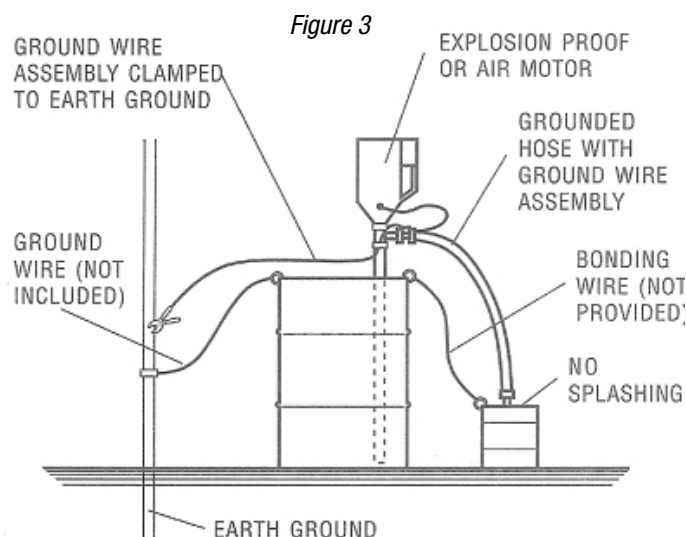

Ground wire attachment to motors:

Air Motor:

1. Remove one of the Allen head set screws (item 8) from the motor mount (item 2).
2. Slide the ¼-20 x 1-1/4" long round head machine screw through the 1/4" ring terminal on ground wire assembly.
3. Thread ¼-20 plated nut onto the screw.
4. Insert the screw into the hole on the motor mount and tighten (do not over tighten).
5. Using a 7/16" wrench, tighten the ¼-20 nut against the ring terminal.

Drum Pump Installation:

1. Install the pump and Static Protection Kit as described and shown in Figure 3.
2. Connect the ground wire assembly to an earth ground using the supplied clamp.
3. Connect the ground wire between the drum and the earth ground.
4. Connect the ground wire between the receiving container and earth ground (or use a bonding wire to connect to the drum).
5. Check electrical continuity of all components before pumping. All should be one (1) Ohm or less.
6. Avoid splashing when operating the pump. Splash filling can create static electricity.

Operation

1. Turn the air motor ball valve to the closed position.
2. Attach the air motor to an air supply line filtered, lubricated (use detergent SAE #10 oil) and regulated to 2.8 bar @ 12.7 lps using a ¼" FNPT fitting. (Note: Finish Thompson offers an optional Filter / Lubricator, P/N A100009.)
3. Insert the pump tube into the fluid to be dispensed and the hose in the container to be filled.
4. While holding the air motor ball valve and hose, slowly turn the valve to the desired flow rate. (**Note:** Pump performance will vary depending on air pressure & volume.)
See figure 4.



Figure 4

EFS Maintenance

Disassembly

1. Prior to pump disassembly remove the motor and static protection kit hose & grounding cable.
2. **Diffuser Cover Removal** - Remove the "Diffuser Cover" (item 19) by turning it clockwise (left hand thread) while gripping the "Diffuser" (item 17). *See figure 5.*
3. **Impeller Removal** - While holding the pump's coupling insert (item 1) or coupling half (item 2), turn the impeller (item 18) counterclockwise (right-hand thread) and remove it. *See figure 6.* If the Coupling Half unthreads rather than the Impeller, repeat the process, but while holding the top of the shaft threads with pliers.
4. **Bearing & Shaft Removal** - Once the Impeller is removed, place a wooden board or rubber mat on the floor (to protect the threads on the bottom of the shaft) and gently tap the shaft on it until the bearing (item 3) is exposed at the top of the pump.



Figure 5



Figure 6

Note: Bearing and shaft should only be removed if seal is worn and leaking, or bearing is hard to turn or frozen otherwise leave it pressed into the head assembly item 16.

5. Pull the bearing and shaft out through the top of the pump. *See figure 7.*
6. Diffuser Removal - Now unthread the “Diffuser” by turning it clockwise (left hand thread). *See figure 8.*
7. Inner Tube & Shaft Sleeve Removal - The outer tube and head for the EFS is welded together. To remove the inner tube and shaft sleeve (items 13 & 15) hold the outer tube and head assembly in a vertical position, and the shaft sleeve will fall out. To remove the inner tube, “pretend” to hit the bottom of the pump on the floor but stop before it actually hits. This motion will allow the weight of the inner tube to release the o-rings, and it will drop out of the bottom of the pump. It is recommended to do this over a soft surface to prevent damaging the inner tube as it drops out of the pump.
8. Seal Removal- To remove the seal (item 5) from the pump head assembly (item 16) use a hook tool, available at most hardware stores, to pull the seal out from the top of the head assembly. Take care not to damage the seal seat area. *See figure 9.*



Figure 7



Figure 8

Inspection

1. Check the “Diffuser Cover” (item 19), the impeller (item 18), and the “Diffuser” (item 17) for wear, rubbing or damage from foreign objects. Replace if damaged.
2. Inspect the shaft (item 4), “Shaft Sleeve”, and seal for wear. Replace the worn parts as needed.
3. Inspect the “Diffuser Bushing” (item 20) for internal wear. Inspect all o-rings (items 12 & 21) for nicks or chemical attack. Replace as needed.
4. Inspect the bearing (item 3) for rust or corrosion.
5. If the bearing needs replaced, it is offered only in a shaft replacement kit, which includes the bearing pre-pressed onto the shaft & a new half coupling. If replacing shaft, also replace the seal item 5.



Figure 9

Note: Never reuse the old seal.

Reassembly

1. Seal Replacement - Install a new seal (item 5) into the pump head with the grooved side facing the bottom of the pump. *See figures 10 & 11.* Press in place until it sits slightly below the surface.
2. Bearing & Shaft Replacement - If replacing the shaft/bearing, carefully insert the shaft straight through the lip seal (to avoid seal damage) from the top and seat the bearing into the pump head. *See figure 12.*



Figure 10



Figure 11



Figure 12

Reassembly

3. **Shaft Installation** - Slide the shaft down through the seal until the bearing engages the bearing bore in the head. Use any size dowel under 1" (25.4 mm) in diameter and press the coupling half/bearing into place using a press or by lightly tapping with a soft mallet. Note: Do not use excessive force. Unthread the coupling half counter clockwise (right hand thread) to verify that the bearing is seated properly. Reinstall the coupling half. See figure 13.



Figure 13

4. **O-Ring Replacement** - If o-rings are replaced, install 2 inner tube o-rings (item 12) in the upper grooves of (item 13). See figure 14. Install the Diffuser o-rings (item 21) inside the top of the Diffuser (item 17). See figure 15. Apply a small amount of Vaseline to the o-rings to aid in assembly.
5. With the pump laying horizontally on a bench, slide the Inner tube (item 13) into the outer tube (item 16) using the shaft as a guide push the o-rings up into the head until they seat. See figure 16.
6. Slide the shaft sleeve into the inner tube. Shaft Sleeve is free floating, Diffuser (item 17) will hold it in place. See figure 17.



Figure 14



Figure 15



Figure 16



Figure 17

7. Slide the Diffuser (item 17) over the shaft and thread into the Outer Tube (left hand thread). May require a slight push to engage the threads. See figures 18 & 19.
8. Gripping the coupling insert or coupling half at the top of the pump, thread the impeller on (right hand thread). DO NOT overtighten. There should be about a 1/16" gap between the Impeller and Diffuser. Install the Diffuser cover (left hand thread). See figure 20.
9. Turn the coupling to verify there is no binding inside the pump.



Figure 18

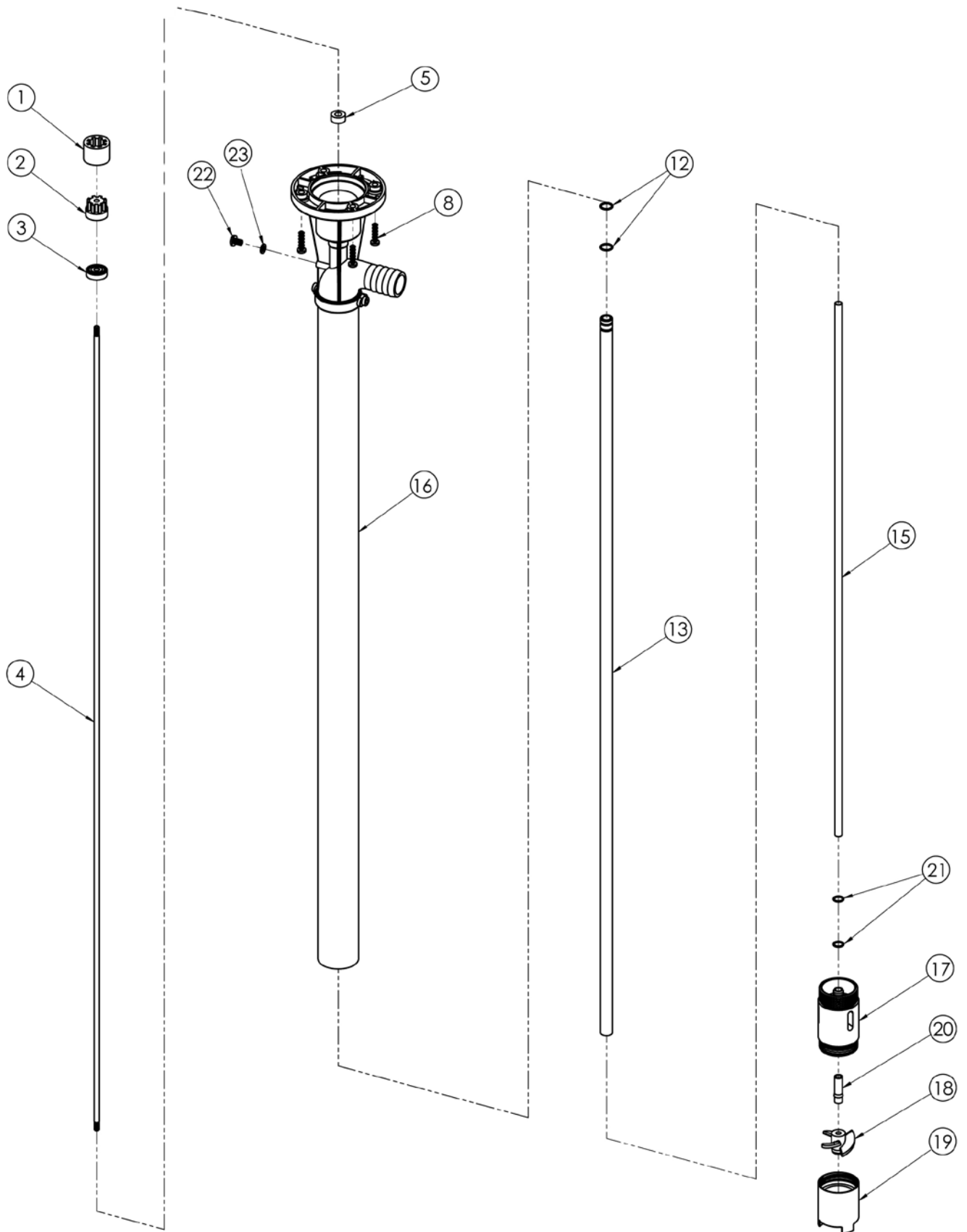

Figure 19



Figure 20

EFS ATEX SPARE PARTS EXPLODED VIEW



EFS ATEX SPARE PARTS LIST

ITEM	QUANTITY	DESCRIPTION	PART NUMBER
1	1	COUPLING INSERT	
			J103422
*2, 3, 4	1	EFS ATEX REPAIR KIT (COUPLING HALF, BEARING & SHAFT)**	
		16"	107589-1
		27"	107589-2
		40"	107589-3
		48"	107589-4
(2)	(1)	COUPLING HALF (IF PURCHASED SEPARATELY FROM KIT)	107300
*5	1	SEAL	
		FKM - USE WITH FKM O-RINGS	107297
		EKONOL - USE WITH PERLAST OR EPDM O-RINGS	108701
8	4	SCREW	
		8-32 - SS	110006
9	1	LOCK WASHER	
		SS	106322
*12	2	INNER TUBE O-RING	
		FKM	107299
		PERLAST	110001
		EPDM	107729
13	1	INNER TUBE	
		16" - 316SS	107578-1
		27" - 316SS	107578-2
		40" - 316SS	107578-3
		48" - 316SS	107578-4
*15	1	SHAFT SLEEVE	
		16" - CARBON FILLED PFA	110007-1
		27" - CARBON FILLED PFA	110007-2
		40" - CARBON FILLED PFA	110007-3
		48" - CARBON FILLED PFA	110007-4
16	1	OUTER TUBE w/ HEAD	
		16"	107580-1
		27"	107580-2
		40"	107580-3
		48"	107580-4
17 [†] , 19 [†] , 20, 21	1	DIFFUSER KIT[†] (DIFFUSER, COVER, BUSHING, & O-RING)	
		316SS w / PTFE BUSHING & FKM O-RINGS	110115
		316SS w / PTFE BUSHING & PERLAST O-RINGS	110116
		316SS w / PTFE BUSHING & EPDM O-RINGS	110117
*18	1	IMPELLER	
		TEFZEL (WHITE)	107067-2
(20)	(1)	DIFFUSER BUSHING (IF PURCHASED SEPARATELY FROM KIT)	
		PTFE	107585
(21)	(2)	DIFFUSER O-RING (IF PURCHASED SEPARATELY FROM KIT)	
		FKM	107586
		PERLAST	110002
		EPDM	107766
22	1	GROUNDING SCREW	
		BRASS	J100822
23	1	GROUNDING SCREW LOCK WASHER	
		BRASS	J100823

*Recommended spare parts

**Coupling half included in kit, but can be purchased separately. Bearing and shaft are only available in the repair kit.

[†]Item number 17 and 19 sold as part of a kit only to ensure proper fit. Item 20 and 21 are available as part of kit or separately.

S4A AIR MOTOR SPARE PARTS EXPLODED VIEW

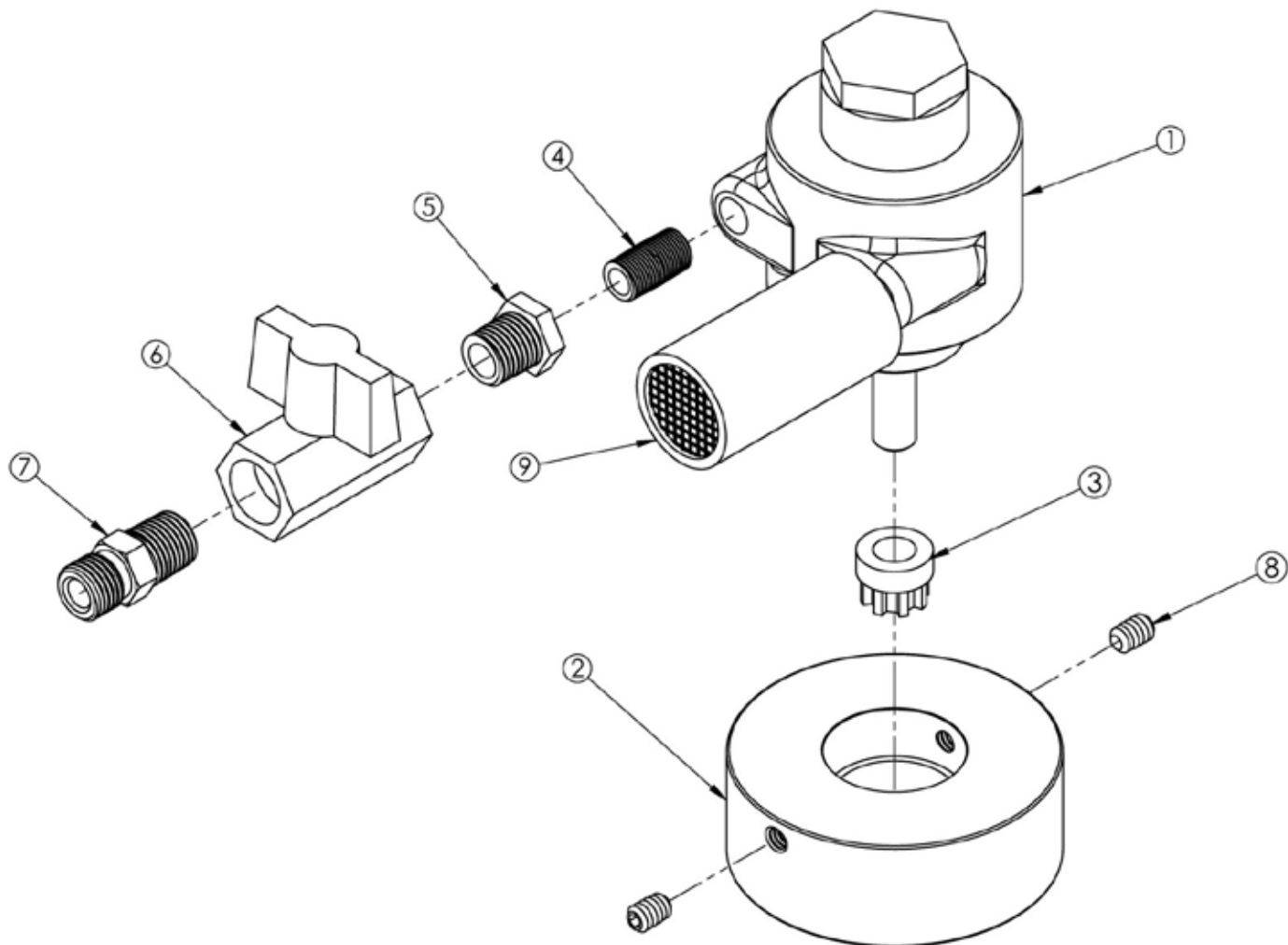

S4 AIR MOTOR SPARE PARTS LIST

ITEM	QUANTITY	DESCRIPTION	PART NUMBER
1	1	AIR MOTOR ONLY	J100032
2	1	AIR MOTOR ADAPTER	107073-1
3	1	COUPLING HALF	J103934
4	1	NIPPLE	J100107
5	1	HEX REDUCER BUSHING	J100057
6	1	BALL VALVE	J100073
7	1	UNION (BRASS)	J100036
8	2	SET SCREW	J100040
9	1	MUFFLER	J100033
N/S	1	AIR MOTOR REPAIR KIT (INCLUDES MUFFLER, FILTER, VANES, GASKETS, & BEARINGS)	J100060
N/S	1	FILTER / LUBRICATOR (OPTIONAL)	A100003
N/S	1	COUPLING INSERT	J103422

N/S = NOT SHOWN



Physical Technical Testing Institute
Ostrava – Radvanice



EC-Type Examination Certificate

- (1) **Equipment or Protective Systems Intended for Use in Potentially Explosive Atmospheres (Directive 94/9/EC)**
- (2) **EC-Type Examination Certificate Number:**
- FTZÚ 14 ATEX 0210X**
- (4) **Equipment or protective system:** Drum pumps of type EFS ...
- (5) **Manufacturer:** FINISH THOMPSON INC.
- (6) **Address:** 921 Greengarden Road, Erie, PA 16501-1591, USA
- (7) This equipment or protective system, and any of accessible variation thereto is specified in the schedule to this certificate and the documents therein referred to.
- (8) The Physical Technical Testing Institute, notified body number 1026 in accordance with Article 9 of the Council Directive 94/9/EC of 23 March 1994, certifies that this equipment or protective system has been found to comply with the Essential Health and Safety Requirements relating to the design and construction of equipment and protective systems intended for use in potentially explosive atmospheres given in Annex II to the Directive.
- The examination and test results are recorded in confidential Report N°:
- 140210 dated 15th December 2014**
- (9) Compliance with Essential Health and Safety Requirements has been assured by compliance with:
- EN 12463-1:2009 EN 12463-5:2011**
- (10) If the sign "X" is placed after the certificate number, it indicates that the equipment or protective system is subject to special conditions for safe use specified in the schedule to this certificate.
- (11) This EC-Type Examination Certificate relates only to the design, examination and testing of the specified equipment or protective system in accordance to the directive 94/9/EC. Further requirements of the Directive apply to the manufacturing process and supply of this equipment or protective system. These are not covered by this certificate.
- (12) The marking of the equipment or protective system shall include following:

Ex II 1/2G c IIB T3

This EC-Type Examination Certificate is valid till: **31.12.2019**

Responsible person:

Dpl. Ing. Lukáš Martink
Head of Certification Body



Date of issue: 19.12.2014

Page: 1/3

This certificate is granted subject to the general conditions of the FTZÚ, s.p.
This certificate may only be reproduced in its entirety and without any change, schedule included.
FTZÚ, s.p., Páteků 133/17, 716 07 Ostrava-Radvanice, Czech Republic,
tel +420 595 222 111, fax +420 595 222 872, ftz@ftz.cz, www.ftz.cz



Physical Technical Testing Institute
Ostrava – Radvanice

Schedule

(14) **EC-Type Examination Certificate N° FTZÚ 14 ATEX 0210X**

- (15) **Description of Equipment or Protective System:**
A type EFS drum pump is used for transferring fluids from one container to another. There are different lengths available for the EFS pump and they are as follows: 41, 50, 102 and 122 cm. Each pump has the same construction materials and design. The pump consists of an impeller housed in stainless steel impeller housing. A stainless steel shaft is running through the pump tube and is supported by two bushings, drives the impeller. EFS pump can handle fluids up to 100°C and 330 cP. The pump is connected to earth ground by a static protection kit or according to the user manual.

(16) Report No.: 140210 dated 15.12.2014

- (17) **Special conditions for safe use:**
17.1 The pump must be grounded before each pumping.
17.2 Operating temperature of medium – max. 100 °C.
17.3 Ambient temperature – range: -18 °C to +40 °C.

- (18) **Essential Health and Safety Requirements:**
18.1 Covered by standards mentioned in (9) of this certificate.
18.2 At installation and operation of pump observe requirements of manual.

Responsible person:

Dpl. Ing. Lukáš Martink
Head of Certification Body



Date of issue: 19.12.2014

Page: 2/3

This certificate is granted subject to the general conditions of the FTZÚ, s.p.
This certificate may only be reproduced in its entirety and without any change, schedule included.
FTZÚ, s.p., Páteků 133/17, 716 07 Ostrava-Radvanice, Czech Republic,
tel +420 595 222 111, fax +420 595 222 872, ftz@ftz.cz, www.ftz.cz



Physical Technical Testing Institute
Ostrava – Radvanice

Schedule

(14) **EC-Type Examination Certificate N° FTZÚ 14 ATEX 0210X**

(18) **List of Documentation:**

- Technical description (13 pages)
- Drawings No.:

R101603 rev.1	dated 03/01/2014
108825-1 rev.7	dated 24/05/2014
107822-1 rev.7	dated 03/06/2014
107882 rev.5	dated 26/02/2014
107883 rev.3	dated 24/02/2014
107885 rev.1	dated 26/02/2014
107884 rev.3	dated 24/02/2014
107577 rev.3	dated 26/02/2014
107578 rev.1	dated 26/02/2014
107296 rev.4	dated 26/02/2014
107296 rev.4	dated 26/02/2014
110207 rev.1	dated 29/08/2014
110008 rev.1	dated 29/08/2014
108701	dated 11/02/2014
107067 rev.4	dated 26/02/2014
107300 rev.1	dated 26/02/2014
107853 rev.2	dated 26/02/2014
107852 rev.1	dated 26/02/2014
107851 rev.1	dated 26/02/2014
107848 rev.1	dated 26/02/2014
A100831 rev.12	dated 26/02/2014
107073-1 rev.0	dated 26/02/2014
110000 rev.2	dated 18/12/2014

Responsible person:

Dpl. Ing. Lukáš Martink
Head of Certification Body



Date of issue: 19.12.2014

Page: 3/3

This certificate is granted subject to the general conditions of the FTZÚ, s.p.
This certificate may only be reproduced in its entirety and without any change, schedule included.
FTZÚ, s.p., Páteků 133/17, 716 07 Ostrava-Radvanice, Czech Republic,
tel +420 595 222 111, fax +420 595 222 872, ftz@ftz.cz, www.ftz.cz



FINISH THOMPSON INC.

921 Greengarden Road • Erie, PA 16501-1591 U.S.A.

Ph 814-455-4478 • Fax 814-455-8518

Email fti@finishthompson.com • www.finishthompson.com

EU DECLARATION OF CONFORMITY

Finish Thompson Inc. hereby declares that the following machines fully comply with the applicable health and safety requirements as specified by the EU Directives listed. This declaration is valid provided that the devices are fully assembled and no modifications are made to these machines.

Type of Device:

Drum or Container Pump

Pump Models:

EFS16 ATEX, EFS27 ATEX, EFS40 ATEX, EFS48 ATEX

EU Directives: Equipment and protective systems intended for use
in potentially explosive atmospheres (2014/34/EU)

EU-Type Examination:

Physical Technical testing Institute 1026

Ostrava-Radvanice

FTZU 14 ATEX 0210X

Product Quality Assurance Notification:

Physical Technical Testing Institute 1026

Ostrava-Radanice FTZU 08 ATEX Q 003

Applicable Harmonized Standards:

EN 1127-1: 2011

EN 13463-1:2009

EN 13463-5:2011

Casey D. Bowes
CEO and President
1 August 2016



EU DECLARATION OF CONFORMITY

Finish Thompson Inc. hereby declares that the following machines fully comply with the applicable health and safety requirements as specified by the EU Directives listed:

Type of Device:

Pump Motor

Pump Motor Models:

S4A

EU Directives:

Equipment and Protective Systems Intended For Use In Potentially
Explosive Atmospheres (2014/34/EU)

Applicable Harmonized Standards:

DIN EN 1127-1:2011

DIN EN 13463-1:2099

DIN EN 13463-5: 2011

The products are marked with the following characteristics:

Ex II 2 GD c T4+1°C<Ta<+40°C

Documentation archived in FTZÚ Ostrava Radviance, EU code 1026

This declaration is valid provided that the devices are fully assembled and no modifications are made to these machines.

Casey D. Bowes

CEO and President

2016 August 1



FINISH THOMPSON INC.
921 Greengarden Road • Erie, PA 16501-1591 U.S.A.
Ph 814-455-4478 • Fax 814-455-8518
Email fti@finishthompson.com • www.finishthompson.com

EU Declaration of Conformity



Finish Thompson Inc. hereby declares that the following machine(s) fully comply with the applicable health and safety requirements as specified by the EU Directives listed. The product may not be taken into service until it has been established that the driven Drum and Container pump complies with the provisions of all relevant EU Directives. The complete product complies with the provisions of the EU Directive on machinery safety provided pumps manufactured by Finish Thompson Inc. are used.

This declaration is valid provided that the devices are fully assembled and no modifications are made to these devices.

Type of Device:

Air Motors for Driving Drum and Container Pumps

Models:

M6	M6X	M18	M19	M20	M57
	M65	M66	S4	S4A	

EU Directives:

Machinery Safety (2006/42/EU)

Applied Harmonized Standards:

EN ISO 12100
EN 983

Manufacturer:

Finish Thompson Inc.
921 Greengarden Road
Erie, Pennsylvania 16501-1591 U.S.A

Signed,

President

1 August 2016

Person(s) Authorized to Compile Technical File: Finish Thompson GmbH
Otto-Hahn-Strasse 16
Maintal, D-63477 DEU
Telephone: 49 (0)6181-90878-0



FINISH THOMPSON INC.

921 Greengarden Road • Erie, PA 16501-1591 U.S.A.

Ph 814-455-4478 • Fax 814-455-8518

Email fti@finishthompson.com • www.finishthompson.com

Service 1-800-888-3743

P/N 110003 Rev. 0, 3/13/2015