



Model FT15ZS Metallic

AIR OPERATED DOUBLE DIAPHRAGM PUMPS

Specifications

| | |
|-------------------------------|-----------------------|
| Suction & Discharge Size: | 1.5" x 1.5" |
| Porting Location: | Center Horizontal |
| Connection Types*: | FNPT, BSPT |
| Air Inlet & Air Exhaust Size: | 1/2" FNPT x 3/4" FNPT |

*Optional ANSI/DIN/ISO flange or 2" tri-clamp connection upgrade available upon request

Capabilities

| | |
|------------------------------|--------------------------|
| Maximum Flow Rate: | 133 gpm (503 lpm) |
| Maximum Air Supply Pressure: | 120 psi (8.3 bar) |
| Displacement Per Stroke: | 0.23 gal (0.91 lit) |
| Minimum Air Inlet Pressure: | 10 psig (0.7 bar) |
| Maximum Particle Size : | 0.38 in (9.7 mm) |
| Sound Pressure: | 77 dB(A) |
| Operating temperature: | Determined by elastomers |



FT15Z Performance

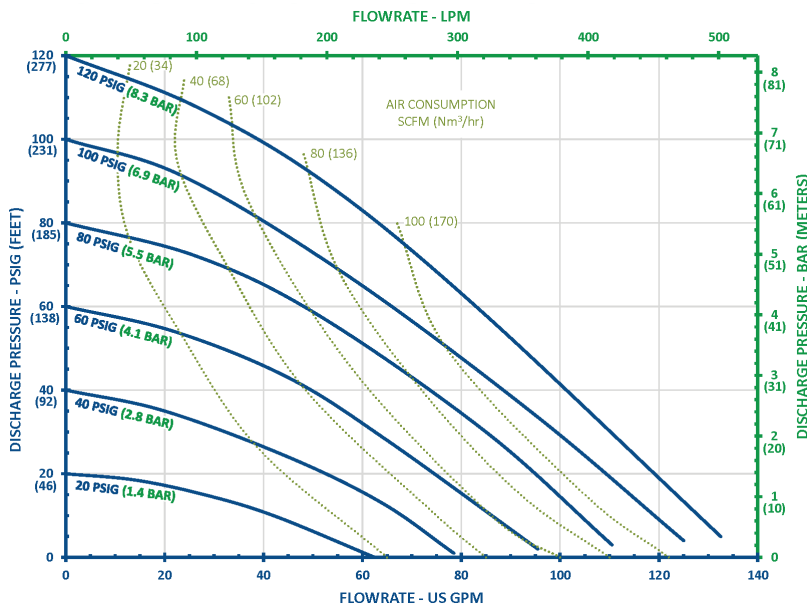

Note: Full stroke diaphragm allows performance to be equal for all elastomers.

Typical Applications

- Acids & Bases
- Plating Solutions
- Wastewater
- Paints, Inks, Solvents
- Ceramic Slip and Glaze
- Lubricants and Oils

Typical Industries

- Mining
- Paints and Coatings
- Ceramics
- Pulp and Paper
- Electroplating & Anodizing
- Wastewater
- Marine
- Chemical Manufacturing & Distribution
- OEM's

CHANGE IS IN THE AIR

Construction

| | |
|----------------------|--|
| Wetted Materials: | 316SS |
| Diaphragm Materials: | Neoprene, Santoprene™, FKM, EPDM, PTFE, Buna, Hytrel®, Polyurethane |
| Air Valve: | GFRPP, Aluminum |
| Ball Materials: | Neoprene, Buna, EPDM, FKM, Santoprene™, PTFE, 316SS |
| Seat Materials: | Aluminum, 316SS, PTFE, Hytrel®, Buna, Neoprene, EPDM, FKM, Santoprene™, Polyurethane |
| O-ring Materials: | Neoprene, Buna, EPDM, FKM, PTFE, FEP/FKM, Santoprene™, Polyurethane |

Santoprene™ is a registered tradename of Exxon Mobil Corp.
 Hytrel® is a registered tradename of Dupont™

Dimensions

| | |
|-----------------|----------------------|
| Maximum Height: | 18-31/32 in (482 mm) |
| Maximum Width: | 19-7/16 in (494 mm) |
| Maximum Depth: | 11-13/32 in (290 mm) |

Weight

| | |
|--------|-----------------|
| 316SS: | 98 lb (44.5 kg) |
|--------|-----------------|

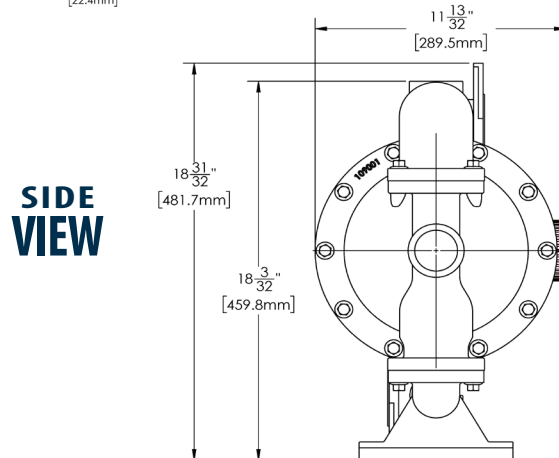
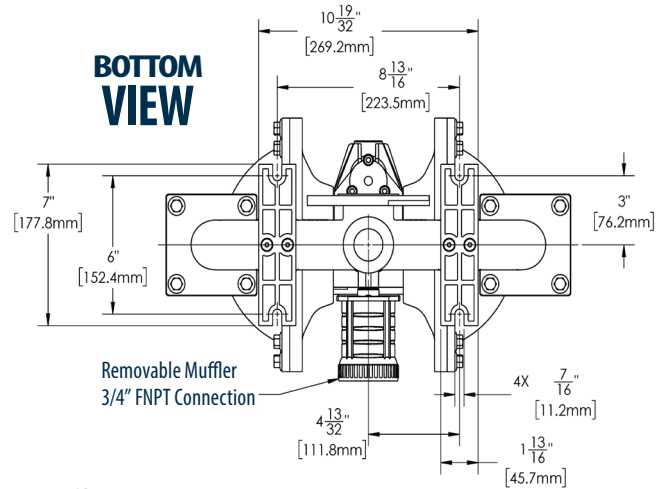
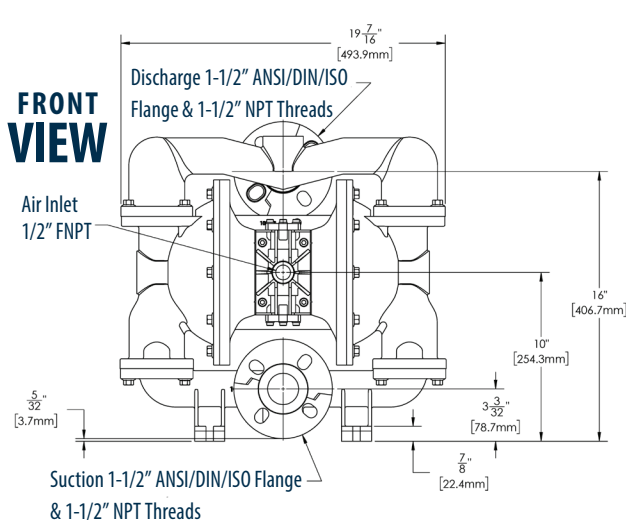

FTI AIR

921 GREENGARDEN ROAD ERIE, PA 16501
 Tel: (800) 934-9384 • Fax: (814) 459-3460
www.FTIAIR.com

