

'G' DISC FILTRATION SYSTEMS MODELS 'CL', 'PL', & PPL

OPERATION AND
SERVICE GUIDE
O-1035
DEC. 2004

SAFETY PRECAUTIONS

BEFORE STARTING PUMP

1. Read Operating Instructions for Disc System, Disc Chamber, Pump and instructions supplied with chemicals to be used.
2. Refer to Chemical Resistance Data Chart for compatibility of materials with solution.
3. Note temperature and pressure limitations of equipment.
4. Personnel operating pump should always wear suitable protective clothing: face mask or goggles, apron and gloves.
5. Do not use piping as handles or steps. All piping must be supported and aligned independently of the pump and chamber.
6. Always close valves slowly to avoid hydraulic shock.
7. Ensure that all fittings and connections are properly tightened.
8. Suction and discharge hose are provided with the filtration system. If piping is to be installed, in lieu of hose, it is recommended to minimize the use of elbows and do not have total pipe length greater than 3/4 that of hose length unless pipe I.D. is larger than hose I.D.

BEFORE CHANGING APPLICATION OR PERFORMING MAINTENANCE

1. Wear protective clothing as described in item 4 above.
2. Flush pump thoroughly with a neutralizing solution to prevent possible harm to personnel.
3. Verify compatibility of materials as stated in item 2 above.

DESCRIPTION

Filter chamber is PVC, CPVC or PP slurry tank is polyethylene. Base is FRP. Piping and valves are CPVC or PP. Filter discs are polypropylene and require individual replacement filter pads. The discs and pads are alternately stacked. Filter media is sealed at center hole and O.D. edge collar of disc.

Pump may be seal-less magnetic drive, single mechanical seal or double mechanical seal. Refer to separate pump operating instructions.

PRE-START-UP

1. Check power source for correct voltage and phase.
2. All pump motors are TEFC and wired for low voltage unless otherwise specified.
3. Screw into place any valves not installed due to crating.
4. Securely fasten hose to hose adapter using metal hose clamps.
5. Inspect all pipe, fittings, filter chamber and pump for any damage due to shipping.
6. If pump assembly includes double water flushed mechanical seal, immediately connect water line to seal assembly. DO NOT start pump without providing water to seal housing and without having a flooded pump suction.
7. Refer to separate operating instructions for PUMP START-UP.
8. For three phase motors, check direction of rotation. Jog motor. Direction of rotation is indicated on pump. If rotation is incorrect, interchange any two of the three wires L1, L2 or L3.

START-UP

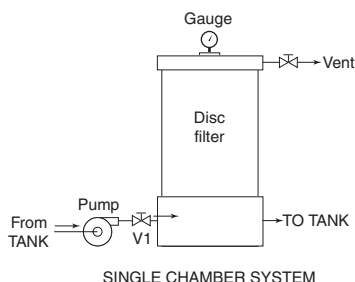

BASIC SYSTEM (Single chamber)

1. Valve V1 may be used as a flow control valve or to reduce flow of high specific gravity solutions when a magnetic drive pump is on the system. Vent the chamber by opening the vent valve. Close the vent valve when the solution appears without bubbles.
2. If filter pads are to be pre-coated, suction and discharge hoses must be placed in a common slurry tank to which filter aid can be added. Refer to PRE-COAT PROCEDURE and table on page 2.
3. After pads have been pre-coated and solution in slurry tank is crystal clear, turn off pump-motor, transfer and secure hoses into plating tank and restart motor.
4. **IMPORTANT:** When transferring suction hose, hold gloved hand over open end of hose to avoid losing prime.

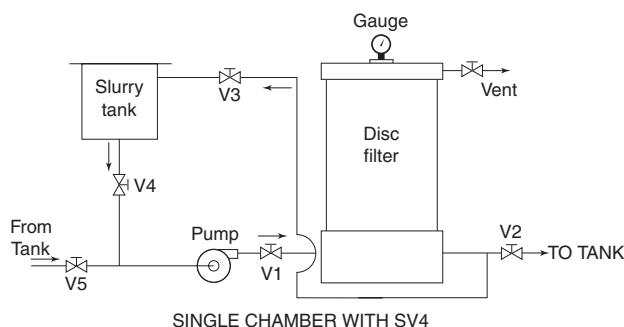

SV4 SYSTEM (Basic plus slurry tank and 4 additional valves.)

1. Priming of the pump is accomplished by using the slurry tank.
2. Place suction and discharge hose in plating tank and securely fasten. Do not locate close to rising bubbles in an air-agitated tank.
3. Close all valves, then open V3 and V4 and vent. Fill slurry tank with water or plating solution. Allow liquid to rise in filter chamber by opening vent.
4. Energize motor, again verifying correct direction of rotation.
5. Slowly open valve V5 to one fourth open. Pump will draw air and solution from suction hose, indicated by increase of liquid in slurry tank. Continue to slowly open valves V5 and V2 while slowly closing valves V4 and V3. Care should be taken to avoid loss of prime or overflow of slurry tank. Open vent to purge air from filter.
6. System is now primed, but filter pads require precoating. Turn valves V3 and V4 to open and valves V2 and V5 to close. Refer to PRE-COAT PROCEDURE. Note, after precoating it is only necessary to open valves V2 and V5 and close V3 and V4 since pump is primed and hoses are already dispelled of air. Transferring flow to plating tank is now a simple task.

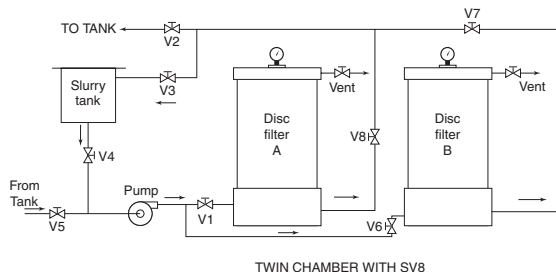

SV8 SYSTEM (Basic plus one chamber and 7 additional valves.)

Priming procedure is the same as - SV4 except isolate Chamber B by closing valves V6 and V7 and vent filter A. Then isolate Chamber A by closing valves V1 and V8 and vent filter B.

PRE-COAT PROCEDURE - FILTER AID

1. With pump operating and recirculating solution between slurry tank and filter chamber, add filter aid in the prescribed amounts shown in chart.

Note: System flow may be reduced by throttling valve V1 and is recommended. A typical rate for water is from 1 to 2 gallons per minute per minute per sq. ft. of filter area (GSFM). It is also suggested to continuously vent air from chamber during precoat cycle since air can be injected via whirlpool effect and agitation of solution in slurry tank. Air will blind discs from precoating.

AREA (Sq.ft.)	FILTER AID (Lbs.)
8	$\frac{3}{4}$ - 1
15	1 $\frac{1}{2}$ - 2
23	2 $\frac{1}{2}$ - 3
31	3 - 3 $\frac{1}{2}$

CAUTION: Insure vent hose goes into tank.

2. With solution recirculating between slurry tank and filter chamber, slowly add prescribed amount of filter aid. This step should take approximately 3 to 5 minutes.
3. Allow recirculation to continue until solution in slurry tank is CRYSTAL CLEAR. This assures proper deposit of precoat. If solution does not become clear, then check inside filter chamber for:
 - A. Omission of disc or filter pad.
 - B. Improper seal of disc column.
 - C. Missing bottom or top gasket.
4. After precoat has been established, open valves 2 and 5 and close valves 3 and 4. System is now on filtration cycle.

PRE-COAT PROCEDURE - POWDERED CARBON

1. After precoating with filter aid, a mixture of powdered carbon and filter aid may be added to the existing precoat.
2. Dry mix equal parts of filter aid with carbon and recirculate until solution in slurry tank is CRYSTAL CLEAR. Then add to recirculating slurry tank in same manner as when precoating with filter aid alone.

CARBON FILTER DISCS

Filter discs impregnated with activated carbon are also available and used totally or in conjunction with the cellulose discs to accomplish the proper degree of organic removal. Depending upon frequency and duration of carbon purification, the filter chamber may be charged with one or several carbon impregnated discs. Install the discs between the polypropylene support plates. Precoating is not recommended when using carbon discs. Install carbon discs at top layers of discs so removal and replacement is convenient.

FILTRATION TIPS

1. Record pressure gauge readings at beginning and end of filtration cycle. It will be valuable in determining establishment of proper precoat and when filter is ready for cleaning. Example: 6 PSI at beginning and 20 PSI at end of cycle (20 GPM).
2. Measure flow rate at beginning of filtration cycle, after pre-coating. This will be the maximum flow attainable. Record the resulting tank turnover per hour. Example: 40 GPM measured flow (2400 GPH) for a 1200 gallon tank is 2 turnovers per hour. At termination of filtration cycle, the flow rate should also be measured and converted to turnovers per hour. If one turnover per hour is decided the minimum desirable flow rate (20 GPM), then note gauge reading and service filter at appropriate pressure, 20 PSI per above example.
3. Powdered carbon will remove, by adsorption, the undesirable and desirable organics. Apply carbon in the amounts recommended by the chemical supplier.
4. Never precoat until chamber is free of air and remains free. Vent continuously, if necessary.

5. Collection of air in the chamber indicates a loose hose or fittings on suction side of pump or that suction hose is drawing air on an air agitated tank.
6. After batch carbon treating, disperse filter aid to the solution surface in treatment tank, allow to settle 5-10 minutes. Filter solution back to tank by following liquid level with hose held only several inches under top of liquid. This allows maximum flow rate during transferring cycle. Be sure filter is properly precoated before starting the transfer cycle.
7. DO NOT OPERATE FILTER UNATTENDED. Pump seal failure, cracked hose, or some other unforeseen occurrence can result in solution loss or damage to equipment.
8. To prevent solution from accidentally being pumped out of tank, position the suction hose at a minimum depth below the liquid level. The suction may be extended to the bottom of the tank if a "vacuum break" hole is provided a few inches below the solution level, when lowered to this point, will cause air to enter the pump suction and cause loss of prime.
9. Piping for the suction and discharge line with both siphon breaker opening and strainer for dispersion holes is shown on SERFILCO Bulletin A-202. CPVC piping for installation purposes is available on Bulletin A-213.
10. Never shut the filter off and start it up without first adding a small additional amount of filter aid to make certain that a cake has been re-deposited in any areas of the media where it may have fallen away from the support membrane.
11. Add additional filter aid depending upon the amount and type of solids, at periodic intervals so the surface of the filter remains porous, and that the flow rate will be maintained at its highest level.

TO SERVICE FILTER AND FILTER DISCS

MODEL – Disc Filter Chamber	PCN
PL15DFO-1-1/2-G3A	78-1721 P
PL30DFO-1-1/2-G3A	78-1722 P
PL45DFO-1-1/2-G3A	78-1723 P
CL15DFO-1-1/2-G3A	78-1721 C
CL30DFO-1-1/2-G3A	78-1722 C
CL45DFO-1-1/2-G3A	78-1723 C
PPL15DFO-1-1/2-G3A	78-1721 PP
PPL30DFO-1-1/2-G3A	78-1722 PP
PPL45DFO-1-1/2-G3A	78-1723 PP

TO REMOVE FILTER DISCS

1. Stop pump and close inlet and outlet valves. Open vent valve and drain. If slurry tank is nearly empty, it will accept overflow when V3 is opened. Loosen cover tee handles and remove chamber cover.
2. Unscrew Disc Stack Top Plate counter clockwise from Center Post.
3. Slide about five filter discs from the center post so you are able to get your hand around the Center Post. Gently rock the Center Post while pulling up. Carefully place the Center Post Disc Stack into the polyethylene pan that has been provided.
4. Remove filter discs. Separate and discard filter paper, spent precoat cake, and contaminants.

TO REASSEMBLE FILTER DISCS

1. Check the two o-rings that are on the bottom of the Center Post for cuts and nicks and replace if damaged.
2. Place filter disc gasket onto Center Post base. Start with Filter Disc onto gasket. Place pre wetted filter paper on each Filter Disc. Filter paper goes between all Filter Discs except top and bottom. Leave about five filter discs out so you are able to get your hand around the center post.
3. Lift Center Post with discs back into the chamber. Line up

Center Post Disc Stack into chamber base center outlet. Rotate Center Post Disc Stack until it locks in place by the Stop Pin. Push Center Post Disc Stack until it is squarely seated.

- Place the remaining filter discs and filter paper onto the center post. Number of filter discs that will fit into the chamber will vary depending on filter paper micron. After the last filter disc is placed on the disc stack, place the filter disc gasket on top of the filter disc.
- Screw Disc Stack Top Plate clockwise onto Center Post. Top Plate should be nearly flush with Center Post.
- Check chamber cover o-ring for cuts and nicks and replace if damaged. Align cover onto shell. Place FRP cover plate on top of chamber cover. Tighten chamber cover by tightening two diametrically opposite tee handles. Tighten remaining tee handles, keeping the cover as even as possible.
- Close drain, open outlet and inlet valves. As the solution rises in the chamber, air will escape at the vent valve. Close the vent valve when the solution appears without bubbles.

OPTIONAL CARBON CHAMBER DESCRIPTION

SERFILCO Carbon Purification Chambers offer a simple, low cost, effective method of removing organic impurities from plating baths and other chemical solutions. The carbon chamber is in series with your filter chamber which traps particulate matter. The granular activated carbon in the carbon chamber removes the organic impurities. Partial flow of the filtered solution is diverted to the carbon chamber by the use of discharge valve V3 on the filter chamber and controlled by carbon inlet valve V9.

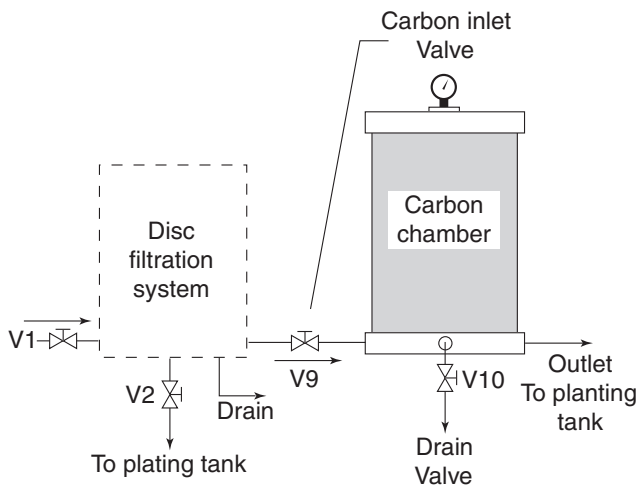

The quality of solution purification using granular activated carbon is dependent upon several factors such as: type of solution, temperature and degree of impurities in solution, type of carbon, depth of carbon and solution contact time (flow rate). Controllable factors are flow rate and type of carbon. A longer contact time between solutions and carbon requires a lower flow rate.

System performance should be established to determine optimum adsorbancy versus flow rate relationship.

The CL3 chamber has bottom hold-down bracket and the CL1 has a CPVC shell cemented into the base. This prevents solution and carbon from draining below the shell when the cover is removed.

Order carbon separately for initial and replacement use.

Two carbon chambers are available for use with Serfilco Disc Filtration System

MODEL	TYPE	CARBON CAPACITY Lbs.	SUGG. FLOW GPM	TRAP FILTER	PORT SIZE NPT
CL1(528C)CCS-1-G3	Single carbon canister	7	1 - 5	SF-03U10U	1"
CL3(528C)CCS-1 1/2-G3A	Three carbon canisters	21	3 - 15	SF-03U10U (3 required)	1 1/2"

CARBON CANISTER START-UP

With filter system in operation, partially open carbon inlet valve V9 to allow solution to flow through the granular carbon. For each canister of carbon, approximately 1-2 gallons of solution is required to flush the carbon free of carbon powder (the result of abrasion when carbon is dry). Solution containing the carbon fines may be poured into the precoat tank and drawn through the filter for removal of the fines onto the precoated discs.

Once the carbon canister discharge runs clear of carbon fines, it will remain clear since the wetted carbon will not abrade.

TO REPLACE CARBON IN CANISTER

NOTE: Be sure that all of the solution has been completely drained out of the carbon chamber and canister before trying to remove the canister. Failure to drain both the canister and carbon chamber will result in a loss of solution.

- Shut off inlet valve V9 to carbon chamber. Open drain valve and allow canister to drain so that all of the solution is removed.
- Remove top cover by loosening the tee handles and lift the cover straight up. Remove spring, cap and canister cover. Lift canister straight up by grasping tee lift handle.
- Drain and pour carbon into polyethylene bag for proper transporting and waste disposal.
- Replace trap filter cartridge, 03U10U, approximately every 3-5 changes of granular carbon. Cartridge is removed by unscrewing tee handle.
- Refill with granular carbon.
- Lower canister into shell and insert hole in center pipe over pipe adapter in base. There is an "O"-ring seal that will prevent solution bypass.
- Replace spring on top of canister. Place cover on shell and tighten tee handle.

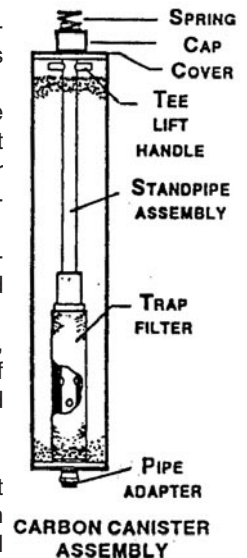

CARBON PURIFICATION TIPS

- SERFILCO By-pass Purification Carbon Chamber is installed on filter discharge with valve V9 on carbon chamber inlet at full open position and valve V2 throttled to allow solution to flow through carbon chamber. Flow through carbon is adjusted to approximately 1-5 GPM per each 7 lb. canister. Continuous recirculation by this method should eliminate or significantly postpone batch treatment with powdered carbon.

2. Full Flow Purification: Valve V2 is closed and valve V9 is opened to provide suitable flow. A low flow rate will provide optimum adsorbency during transfer.
3. A regular analysis of carbon chamber discharge will establish ideal flow rate and indicate when carbon replacement is necessary.
4. A pressure gauge on carbon chamber inlet will permit valve adjustment for repeatedly obtaining identical flow rate.
5. Replacement carbon and filter screens should be ordered and placed in stock for immediate availability for bulk carbon chamber. Use 3 micron trap filter cartridge, 03U10U (10") for each carbon canister.

EQUIPMENT MAINTENANCE TIPS

1. Keep the overall unit clean and dry and avoid splashing any liquid on the motor or starter.
2. Check seals frequently for leakage. Repair immediately when necessary before the solution leakage causes additional damage to the pump or motor.
3. When the pump requires servicing, it is usually easier to remove the pump from the system so that repairs may be made. Refer to separate pump operating instructions.
4. Refer to parts lists provided to order replacements by part number and keep the suggested parts on hand as indicated on the parts lists, so that down-time can be kept to a minimum.

PIPE ASSEMBLY SERVICE GUIDE

The following suggestions are offered when servicing SERFILCO Disc Filtration Systems:

Sometimes solvent sealed piping contains some threaded connections out of necessity. Whenever possible, if pipe has to be removed from the system to service or repair a pump, filter or slurry tank, it is best if the pipe can be removed as a complete assembly. Pipe assemblies can be removed at any valve by removing the union nut at either end of the "true union" valve. The bulkhead fittings in the slurry tank will unscrew from inside the tank. The pump itself splits between the suction casing, which generally includes the inlet and outlet pipe connection, and the support casing which includes the impeller.

ELECTRICAL

If motor fails to start or runs at improper speed or stops after several minutes of operation, TURN MOTOR STARTER OFF. Check electrical source and compare with original order.

Check ampere draw with motor running and compare with full load ampere rating on motor data plate. If greater than data plate rating, reduce flow from chamber by throttling discharge valve V2.



SERFILCO[®], LTD.

2900 MacArthur Blvd. 847-509-2900
 Northbrook, IL 60062-2005 U.S.A. 800-323-5431
 e-mail: sales@serfilco.com FAX: 847-559-1995
 www.serfilco.com