



SERIES 'HA' PLASTIC HORIZONTAL PUMP

OPERATION AND
SERVICE GUIDE
O-0123
MARCH 2006

MODELS:

HA3 x 2F x 6

HA4 x 3F x 8

! SAFETY PRECAUTIONS BEFORE STARTING PUMP

1. Read Operating Instructions and Instructions supplied with chemicals to be used.
2. Refer to a chemical resistance data chart for compatibility of materials in pump with solution to be used.
3. Note temperature and pressure limitations.
4. **Personnel operating pump should always wear suitable protective clothing: face mask or goggles, apron and gloves.**
5. All piping must be supported and aligned independently of the pump.
6. Always close valves slowly to avoid hydraulic shock.
7. Ensure that all fittings and connections are properly tightened.

! BEFORE CHANGING APPLICATION OR PERFORMING MAINTENANCE

1. **Wear protective clothing as described in Item 4 above.**
2. Flush pump thoroughly with a neutralizing solution to prevent possible harm to personnel.
3. **Verify compatibility of materials as stated in Item 2 above.**
4. Shut off power to motor at disconnect switch.

! IMPORTANT

1. **Pump is constructed entirely of plastic, all fasteners are stainless steel. Shafts are stainless steel protected by a plastic sleeve. The plastic may be chemically compatible with the solution being pumped, but care should be taken to protect the pump components against unnecessary wear and abuse. Confirm seal material compatibility.**
2. Record all model and serial numbers for future reference. Always specify model number and serial number when ordering parts.
3. Pump flow curves are based on pumping water. Increased motor horsepower may be necessary for pumping other liquids or reduced motor horsepower may be permissible when pumping at higher discharge head. Refer to pump curve.
4. Impellers are designed to offer maximum pump output and the motors are sized for non-overloading at maximum flow conditions. Impellers may be trimmed to reduce flow and discharge head, if desired. See Parts List for impellers of various diameters.
5. **NOTE: Pump inlet piping should be one to two sizes larger than pump suction size for long suction lines operating near vaporization temperature and low atmospheric pressure (high elevation). Refer to Bulletin**

Refer to Bulletin P-207 and Parts List P-0976, P-0977

for pipe, fittings, etc. Be aware of the high rate of thermal expansion of plastic pipe when piping to a pump. Refer to PRE START-UP instruction No. 10.

6. Review Parts List and maintain an emergency inventory of replacement items to assure that pump is returned to service with the least delay.
7. **Maximum pressure produced by pumps when pumping water -**
! A. 65 PSI on 60 Hz - 3450 RPM motors
B. 310 KPa on 50 Hz - 2850 RPM motors
Do not subject pump to pressures over 22 PSI or 151 KPa, when motor is not running. Mechanical seal faces can separate and leak.
8. When recirculating, use syphon breaker to prevent solution loss due to malfunction.

PRE START-UP

Read items 1-11 below and cavitation supplement page, before starting pump.

1. Verify that operating temperature is not in excess of pump design temperature.
2. Before attaching suction line to pump, turn the impeller slightly to verify free rotation of seal faces.
3. Connect electrical supply to motor starter. If starter is furnished, verify that starter and motor are wired for the correct operating voltage and correct overload heaters. It is recommended that a motor starter be installed for overload protection, if one was not provided with the pump assembly. Wire in accordance with local codes.
4. Wire for counter clockwise rotation when facing the pump suction. **DO NOT** start a motor to check rotation before liquid is in the pump body. Dry rotation of the mechanical seal can cause immediate failure of the seal components. Check pump rotation only with liquid in the pump by **jogging** motor. If pump rotation is incorrect, the motor should be stopped and properly wired. Incorrect rotation causes a reduction in flow rate and can cause pump failure.
5. All units are factory tested to meet published or specified flow rates and to confirm that the seal assembly functioned properly at time of shipment.
6. Some models require a shim under the motor base so that the pump suction casing is above the motor mounting surface. Do not fasten the motor in place without a shim if one is required.
7. Install a strainer on the pump suction line to prevent foreign material from entering the pump and possibly causing impeller damage. The pump is constructed of plastic for chemical resistance and does not have the shock resistance of cast steel.
8. Do not over-tighten suction and discharge connections to the pump body. To prevent leakage at these points,

it is suggested that TFE tape be used on the threads rather than a pipe compound.

9. Do not use double water flushed seal with solutions that have high 'heat of solutions' such as concentrated sulfuric acid which will have an exothermic reaction when mixed with water.

10. **⚠ IMPORTANT:** Suction pipe or hose should **never** be less than diameter of suction. For long suction lines in excess of 15 ft. of hose or 10 ft. of **straight** pipe, the next larger hose or pipe should be used. This is especially important for 2850/3450 RPM models, when pumping at elevated temperature, high elevation, or when the suction line includes several elbows. The preceding conditions contribute to pump cavitation which result in under-performance and premature failure of pump components. Suction pipe velocities should be as low as possible. An increase in suction pipe size will accomplish this. Suction pipe or hose should be as short and straight as possible with a minimum of pipe fittings. This is especially true when liquid being pumped is above ambient temperature. Refrain from using elbows or tees in the suction. Do not install any elbows within 10 pipe diameters of the suction. Using pipe or hose smaller than the suction port size increases the velocity of the fluid and friction loss in the suction line, thereby negatively affecting pump performance or service life.

11. Do not install valve on suction line for throttling/controlling pump flow. Control valve should only be installed on pump discharge.

⚠ IMPORTANT: Considerable damage will result from the rapid temperature rise which will occur if the pump is run against a closed discharge valve. A valve in the suction line should only be used as a stop valve when the pump is removed for servicing. A ball valve is recommended for this application.

12. A Dri-Stop pump protector is recommended for prevention of pump damage during abnormal operation. See Bulletin A-105 and Operation and Service Guides O-1680 & O-1685.

START-UP

1. If pump is installed with a liquid head at the suction line, it will not be necessary to prime the pump. It is only necessary to make sure that liquid is in the suction line and pump body before energizing the motor.
2. If the pump is installed without a positive suction head, proper priming procedure should be followed. It is absolutely necessary that the suction line and pump be completely filled with liquid. If piped in place, liquid for priming may be introduced through the discharge line. If hose connected, liquid for priming may be introduced through the suction hose. Be sure that air is not trapped in the hose.
3. Operate pump for 2 - 4 minutes, then de-energize motor. With bare fingers and after rotation stops, feel metal spring and retainer of seal assembly (only applicable on single seal pumps). If hot to the touch, pump is cavitating and corrective action should be taken before energizing motor. If seal area is not hot, motor may be energized. Refer to supplement.

PUMP SERVICE

1. TO REMOVE SUCTION CASING

Remove the eight 3/8"-16 hex head bolts that hold the suction casing to the support casing. Pull suction casing forward to release it from the "O"-ring seal. Replace suction casing by assembling it to the support casing and fastening with the eight bolts. Tighten in an alternating pattern.

2. TO REPLACE SINGLE MECHANICAL SEAL AND/OR IMPELLER

- A. Remove suction casing as described. Mechanical seal is located inside the sleeve of support casing.
- B. Remove six 3/8"-16 hex head bolts located on inside wall of motor connecting bracket.
- C. Remove motor fan cover and fan.

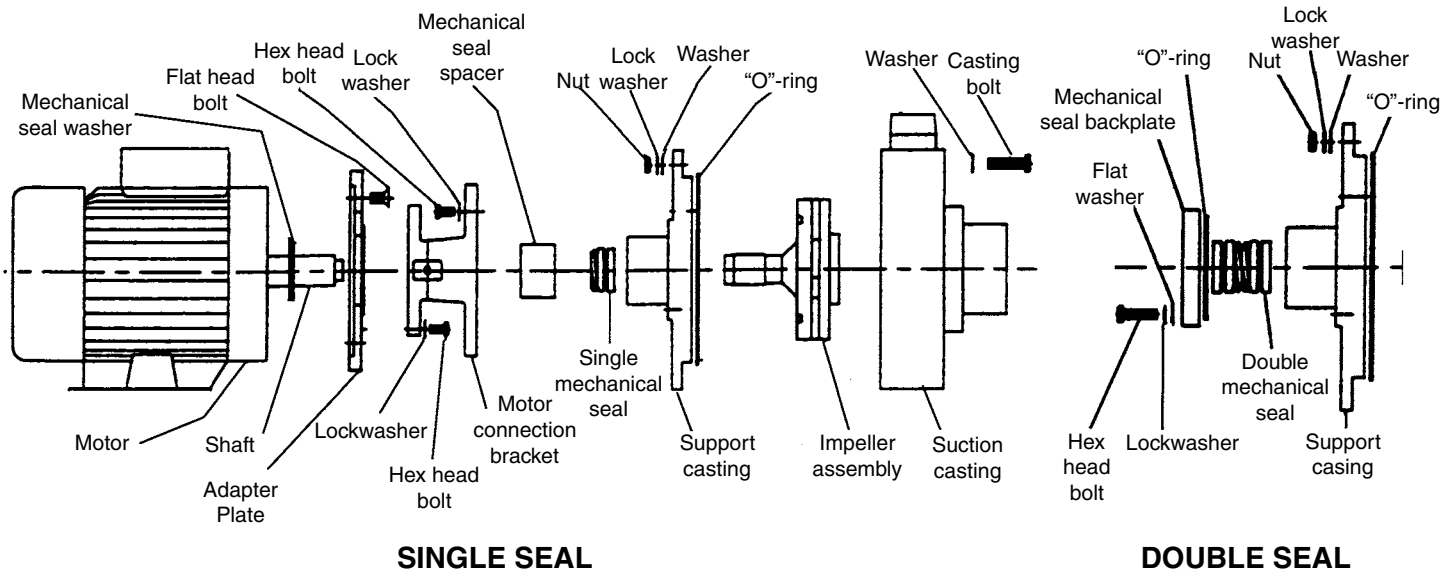

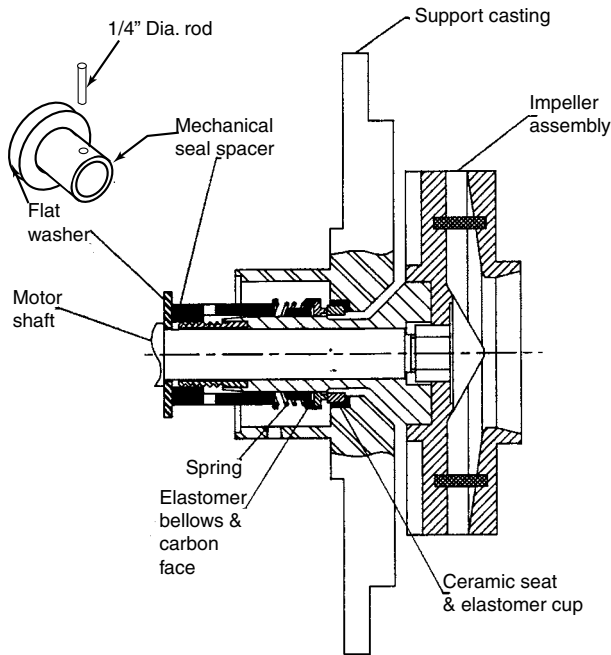

SINGLE SEAL DRAWING

- D. Grip end of motor shaft with vise grips.
- E. Remove impeller by turning counter clockwise using a strap wrench.
- F. Impeller and support casing will come off the motor together.
- G. Insert a 1/4" diameter rod into side of hole of mechanical seal spacer and unthread spacer from the impeller sleeve. Spring and spring holder can be taken off sleeve. To remove bellows, pull impeller sleeve through the support casing.
- H. Mechanical seal ceramic seat can be removed from counterbore at end of support casing by using a piece of plastic pipe that will fit into the end of the support casing. Push the ceramic seat to force it out of its seat.
- I. Flat washer must be left on motor shaft.
- J. Lubricate ceramic seat cup before installing: Viton: vegetable oil or water. Use of non-petroleum products (silicone etc.) may cause problems with chemical solution. EPDM: glycerine or water. Use of petroleum product will react with EPDM and prevent proper sealing. Place support casing into hot water for approximately 5 minutes so that seat recess will expand. Insert ceramic seat and elastomer cup into bottom of support casing sleeve. Use a piece of plastic pipe to push the ceramic seat to bottom of recess. Do not use metal or objects that will scratch the lapped face of the ceramic seat. Check for squareness.
- K. Lubricate impeller sleeve as indicated in Section J. Slide impeller sleeve through ceramic seat leaving a 1/8" clearance between back of impeller and surface of support casing. Slide carbon washer and bellows assembly over impeller sleeve and slide down to the

ceramic seat. We recommend our tool be used to push seal assembly. This insures proper preload on seal faces. Place spring and spring holder on impeller sleeve. Wrap 1 or 2 layers of TFE tape on threads of impeller sleeve. Assemble mechanical seal spacer on impeller until end of spacer is flush with end of sleeve. Lubricate motor shaft with vegetable oil.

- L. Apply "Loctite Thread Lock" on shaft threads. Slide impeller assembly on motor shaft. With a strap wrench, turn impeller clockwise until snug, while motor shaft is locked with vise grips. Assemble support casing to motor connecting bracket with six 3/8"-16 hex head machine screws with flat washer. Do not tighten screws until Step N. Remove temporary 1/4" spacers if used in Step K.
- M. **⚠ IMPORTANT:** Insert a 1/4" diameter steel rod **⚠** into hole in side of mechanical seal spacer and turn the spacer until it backs up to steel washer at end of motor shaft. **⚠ CAUTION:** DO NOT force spacer against flat washer.
- N. Tighten hex head screws on support casing.
- O. Replace suction casing as described in Section 1.

NOTE: It is recommended that a new seal be installed whenever the impeller has been removed from the pump.

3. TO REPLACE DOUBLE MECHANICAL SEAL

- A. Take off water lines to inlet and outlet of seal housing by removing top hex nut at fitting.
- B. Remove suction casing and impeller support casing assembly as described in section 2-A to 2-F. Mechanical seal is located inside the sleeve of the support casing.
- C. Remove mechanical seal back-plate by taking out four 5/16"-18 hex head bolts.
- D. Remove impeller from support casing by placing end of impeller sleeve on table. Grasp the support casing by the outer edge and push the impeller sleeve through the mechanical seal bellows that is in the seal housing.
- E. Mechanical seal ceramic seat can be removed from end of support casing by using a piece of plastic pipe that will fit into the end of the support casing. Push the ceramic seat to force it out of its seat. The ceramic seat on the water end can be removed from the back-plate by using a piece of plastic pipe as described for the solution ceramic side seat.
- F. Install ceramic washer and elastomer cup as described in Section 2-J. Note elastomer material identification color code.
- G. Lubricate impeller as described in Section 2-K. Do not lubricate first half of sleeve. Slide impeller sleeve through ceramic seat leaving a 1/8" clearance between back of impeller and surface of support casing.

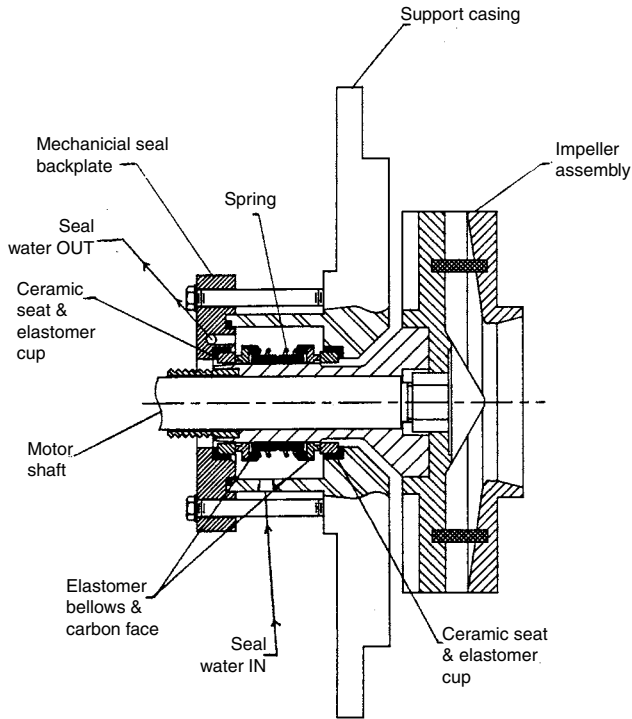

DOUBLE SEAL DRAWING

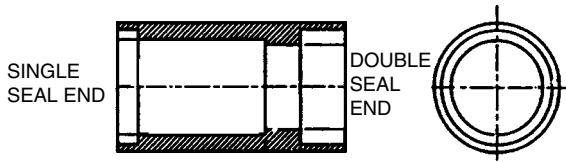

**SEAL INSTALLATION TOOL
PART NO. 44-2730**

1. Assemble solution side bellows on impeller sleeve with carbon face toward ceramic seat and slide the parts down to the ceramic seat. We recommend our tool (single seal end) be used to push seal assembly.
 2. Place spring on impeller sleeve. Put on water side bellows (EPDM) with carbon washer to outside of support casing sleeve. Use double seal end of tool to push seal down.
 3. If seal does not stay down after force is removed, clean off lubricant on this part of sleeve. The tool insures proper preload on seal faces.
- H. Put 'O'-ring in groove at end of support casing sleeve.
- I. Assemble mechanical seal back-plate to support casing with four 5/16"-18 hex bolts and flat washer.
 - J. Assemble support casing with impeller and fasten to motor connecting bracket as described in Section 2-L. Remove temporary 1/8" spacers if used in Step K.
 - K. Tighten hex head screws on support casing.
 - L. Replace suction casing as described in Section 1.

4. TO REPLACE SUPPORT CASING

See Section 2 or 3.

5. TO REPLACE MOTOR

- A. Remove suction casing as described in Section 1.
- B. Remove impeller and support casing as outlined in Section 2 or 3. Remove the 3/8"-16 x 1" long hex head machine screws holding the motor connecting bracket to the motor end bell.
- C. While motor shaft is locked with vice grips, unscrew (turn ccw) pump shaft from motor shaft with a pipe wrench.
- D. Assemble pump to motor by:
 1. Fastening motor connecting bracket to motor.
 2. Apply "Locktite Thread Lock" to pump shaft threads and install shaft in motor.
 3. Assemble impeller and support casing as outlined in Section 2 for single seal, and in Section 3 for double seal.

6. INSTALLATION OF DRI-STOP PUMP PROTECTOR - SINGLE MECHANICAL SEAL PUMP (See Bulletin A-105 and Operation and Service Guide O-1680)

- A. Dri-Stop 3 Pressure Switch Pump Protector assembly should be assembled to a tee fitting installed in the pump discharge pipework.
- B. The unit is designed to operate from a 24V-115V-230V-1/50-60 supply.
- C. Switch contacts are pressure sensitive and close at approximately 4 PSI. These contacts should be wired in series with the coil of a suitable push button motor starter equipped with a set of contacts which are momentarily made when start button is pressed. These contacts are connected such that they short out the Dri-Stop Switch contacts to enable the motor to be energized.

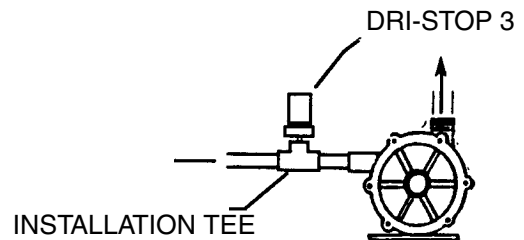

- D. Head/pressure of liquid generated at the pump discharge keeps the Dri-Stop contacts closed and the motor energized until such time that the absence of liquid allows the switch contacts to open and de-energize the motor.
- E. The Dri-Stop pressure switch provides effective protection in circumstances where the supply of liquid to the pump is instantaneously interrupted, eg. tank is empty; suction pipe leaks.

7. INSTALLATION OF DRI-STOP PUMP PROTECTOR-DOUBLE WATER FLUSHED MECHANICAL SEAL PUMP
(See Bulletin A-105 and Operation and Service Guide O-1685).

! Double mechanical seal pumps require a constant flow of fresh water when pump is in operation.

- A. Dri-Stop 2 Flow Switch should be installed in the water outlet line from the seal housing.
- B. It is recommended that a valve be fitted to the outlet of the switch unit to enable adjustment of flow rate.
- C. The unit is designed to operate from a 24V or 115V or 230V/1/50-60 supply. It has a relay with open contacts when the rotor is stationary. Flow of water through the unit causes the rotor to rotate and close the contacts which are connected in series with the coil of the motor starter.
- D. The motor can only be energized when water is flowing through the seal housing causing closure of the switch contacts. Interruption of the water supply will cause the starter to trip, de-energizing the motor.
- E. **For optimum seal performance and longevity, an incoming flow of 8 GPH@15 PSI above pump operating pressure must be provided to the seal chamber. The seal will operate with lower incoming water pressure under certain conditions. Provide the following operating conditions to SERFILCO'S Application Engineering Department to confirm suitability of the application with lower water pressure to the seal chamber:**

- | | |
|------------------|------------------------|
| - NPSH available | - Pump operating PSI |
| - Motor HP | - Solution S.G. |
| - Motor RPM | - Solution temperature |
| - Operating flow | - Solution content |

TROUBLESHOOTING

1. **MOTOR STOPS:** Check for correct voltage, wiring and proper overload heaters in motor starter. Take an ammeter reading at operating conditions and compare to value shown on motor nameplate. Measured value should be equal to or less than rated value. Check for friction free rotation of pump by manually turning fan blade.
2. **PUMP DOES NOT DELIVER CORRECT FLOW:** Check suction strainer and pump inlet to be sure neither is plugged with debris. Compare required flow conditions to original specifications and pump curve which is based on water. Check motor running direction. It should be clockwise from motor fan end.
3. **FREQUENT SEAL FAILURE** can be caused by the the following: Abrasives in solution, crystallization on seal components, chemical attack on seal components (see available alternates), improper priming and pump operation while dry, pump sucking air or undersized suction piping causing cavitation and vibration. Worn motor bearings or bent pump shaft may also be causes of failure. Always flush pump with clean liquid after pumping solutions that could crystallize during pump shut-down.
4. Review parts list and maintain an inventory of recommended spare parts for replacement. This will assure that the pump is returned to operation with minimum delay.

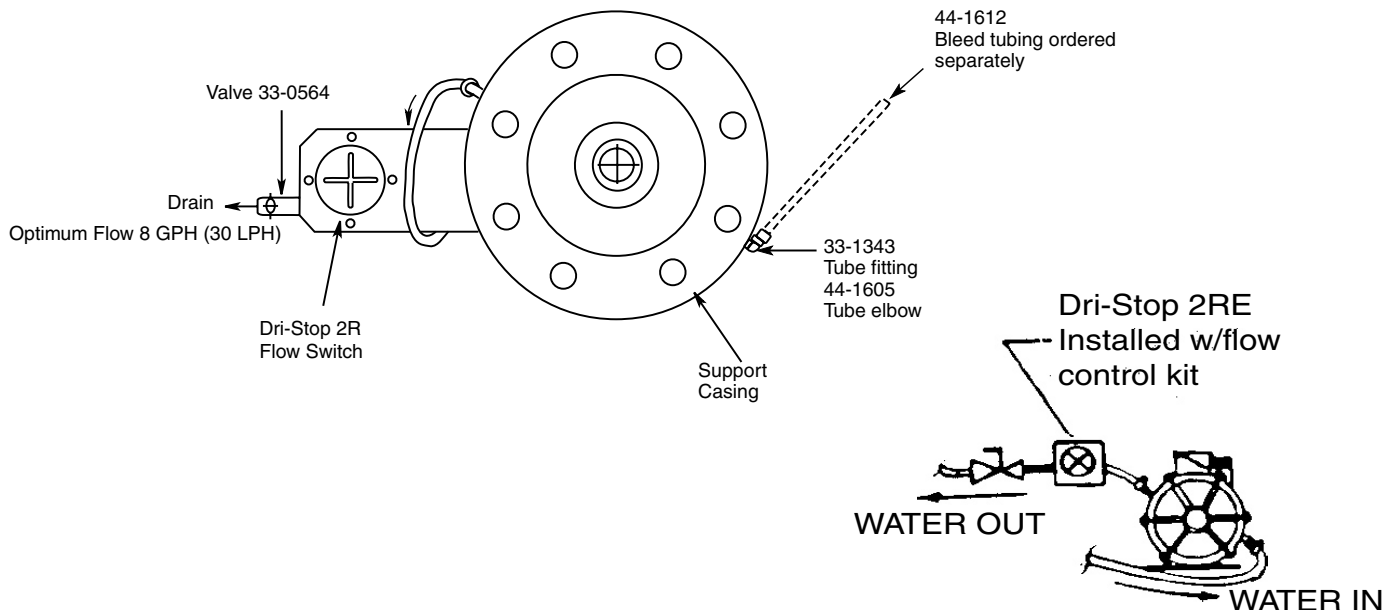

CAVITATION OR 'STARVATION' OF SINGLE MECHANICAL SEAL SERIES 'H' PUMPS

Dry operation and cavitation can cause seal failure in an identical manner, "burning" of plastic seal plate. It is the duration of these operating conditions which determines the degree of burning. **A charred impeller sleeve** is the result of short duration of dry operation or cavitation. **A charred impeller sleeve and charred seal support plate** is the result of longer dry operation or cavitation.

It is imperative that all users are alerted to the conditions which cause cavitation and make sure they are avoided. A pump can operate with some degree of cavitation and apparently not fail.

CAVITATION - STARVATION

A review of the 'H' pump flow curve shows that for all combinations of flow and TDH, there is a required NPSH. If the "**available**" is less than the "**required NPSH**", the pump will cavitate. This does not necessarily imply that the pump will immediately fail, or that it will not function to **apparent** stated performance. Cavitation means that the pump is operating inefficiently and at less than minimum design conditions. Premature wear or failure can occur and the duration of inefficient operation is not necessarily accompanied by excessive noise and/or vibration.

Cavitation is usually the result of a restricted inlet, such as undersized or long suction pipe or an excess of fittings and flow restrictions on the pump suction line. Conversely, if no inlet restriction, then the pump will perform exactly to the flow curve. Unfortunately it is usually difficult to determine or know if or when a pump is performing "under spec" caused by cavitation because of the difficulty in accurately determining flow and TDH under field conditions. The sound of cavitation is much like pumping gravel.

It has been verified by test that cavitation can cause seal failure within 30 seconds and failure is **identical** to

that of dry operation . . . while pumping 50-60 GPM! The restricted inlet is causing limited flow into the pump and a partial vacuum or a "void of solution" now exists at the seal face. Heat is rapidly generated and radiated from the ceramic-carbon face. Temperatures between the faces and the adjacent plastic reach 450°F. The plastic gets hot and continued operation causes seal failure and charring of the plastic. Note that lowering the pump flow with a valve on the discharge will not affect the pump as being described above.

DAMAGE TO SEAL SUPPORT PLATE

This is caused by the convection of some of the heat which is rapidly generated at the seal face, through the the air space to the support plate itself.

DAMAGE TO IMPELLER SLEEVE

Some of the rapidly generated heat at the seal face is transmitted by convection from the face to the impeller sleeve.

DRY OPERATION

When the pump has been operated dry or has lost its prime and continues to run, seal failure will occur due to excessively high temperatures generated on the mating carbon and ceramic seal faces. Cause of failure can easily be verified by black charring of the plastic sleeve of the impeller assembly and the plastic around the stationary seal area and distortion at rear of seal support plate. Failure can occur within 30 seconds and the degree of failure is strictly dependent upon duration of pump operation. Trying to stop burning (excessive heat) by liquid cooling will thermal shock the ceramic. This can be seen by a ceramic cracked in 2 - 6 places.

The above problem conditions can be avoided. Refer to Page 2, Pre Start-Up Instructions No. 10 and 11.



SERFILCO®

2900 MacArthur Blvd. 847-509-2900
Northbrook, IL 60062-2005 U.S.A. 800-323-5431
Email: sales@serfilco.com FAX: 847-559-1995
Web: <http://www.serfilco.com>