



LABMASTER 'LX' | FILTRATION SYSTEMS

COMPACT, ECONOMICAL FILTRATION AND PURIFICATION

Flow rates to 600 GPH @ 60 Hz



The SERFILCO **Labmaster 'LX' Series** is engineered to provide reliable, high performance filtration in a small package.

These compact pump and filter systems are popular for use on small tank production in the electronics industry and in precious metal plating, as well as for laboratory and pilot plant runs.

Featuring SERFILCO's non-metallic, leak-proof Series 'X' magnetic coupled pumps and industry proven Series 'L' filter chambers, these systems provide high flow and high turnover rates, assuring continuous particle removal. Labmaster 'LX' systems are available with or without a carbon or resin purification chamber.

- **Seal-less magnetic drive pumps**

Labmaster 'LX' filtration systems feature highly efficient seal-less magnetic coupled pumps for total solution containment and reliable performance to 1.3 S.G. The pumps are available in polypropylene or ETFE.

- **Filter chamber**

Constructed of clear PVC, CPVC, polypropylene or PVDF to ensure chemical and temperature compatibility in a wide range of applications.

The standard chamber accepts double open end (DOE) depth wound, pleated, melt blown, and carbon cartridges. A 222 "O"-ring seat for single open end (SOE) cartridges is available.

- **Simple carbon or resin treatment**

The systems are also available with optional purification chambers in polypropylene, PVC or CPVC with reusable ABS canister offering a low-cost, but effective method of continuously or periodically removing organic impurities from plating baths and other chemical solutions.



SPECIFICATIONS

Standard Labmaster 'LX' systems include:

- System flow rates to 600 GPH
- Series 'X' magnetic coupled pump good to 1.3 S.G.
- Series 'L' filter chamber — for 10", 20" or 30" cartridges
- Corrosion resistant PVC hooded mounting base
- EPDM elastomers standard
- Stainless steel external fasteners
- Polypropylene vent valve or PVDF vent plug
- Order hose kit separately

! CAUTION: Do not use vinyl hose when system is to be used at 150°F (66°C) or higher.

PCL Polypropylene pump, clear PVC chamber*
Systems for mild acid (non-fluoride) and alkalis including electroless copper and gold.

CL Polypropylene pump and CPVC filter chamber*
Systems for nickel sulfamate, acid copper, copper cyanide, zinc chloride and most fluoborate baths

PPL Polypropylene pump and filter chamber*
Systems for nickel sulfamate, acid copper, copper cyanide, and zinc chloride.

KL ETFE pump and PVDF filter chamber*
Systems for nickel acetate seal and hex chrome.

* Consult a chemical resistance guide to confirm material /solution compatibility.

PERFORMANCE

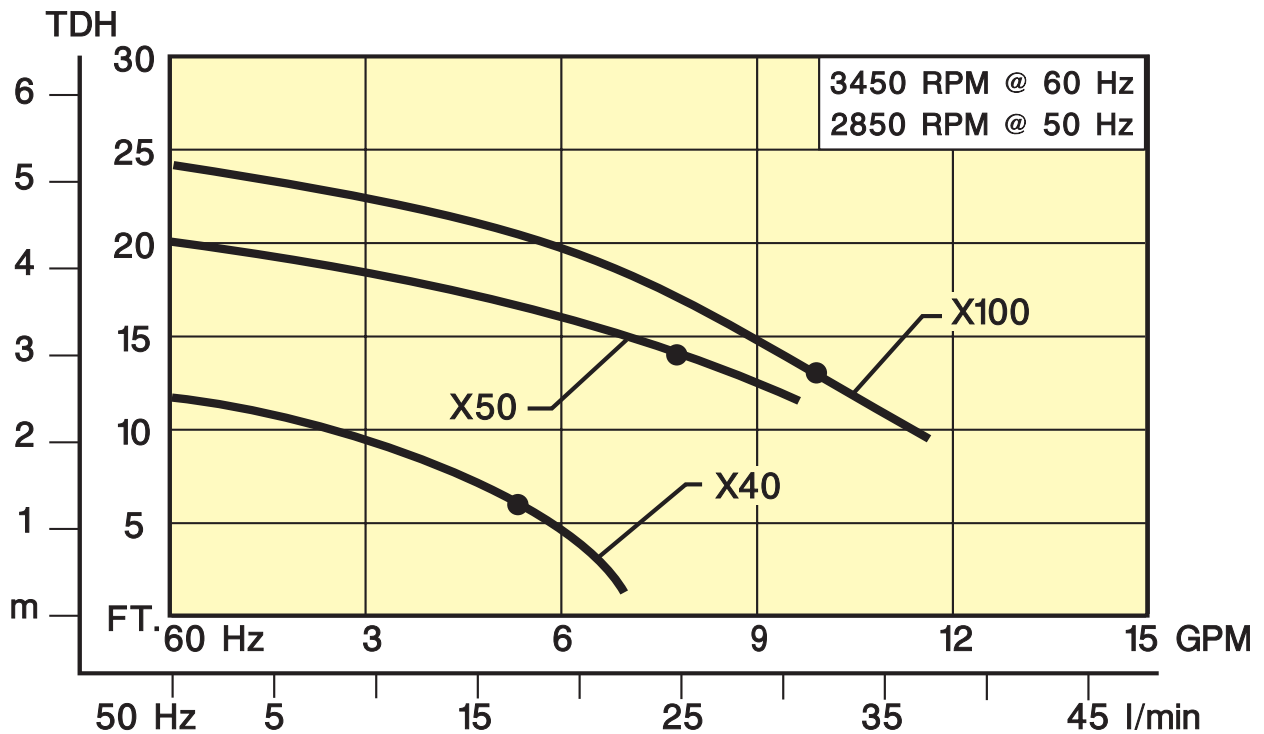

● Realistic system flow



TO ORDER, use System Number

SYSTEM NO.				MEDIA ² No - length.	PUMP			INLET CONNS. ¹	SHIPPING WEIGHT (lbs.)
PCL	PPL	CL	KL ¹		MODEL	HP ³	FLOW ⁴		
PCL1X40	PPL1X40	CL1X40	KL1X40	1 - 10"	X40	1/40	330	5/8" hose barb	25
PCL2X40	PPL2X40	CL2X40	KL2X40	1 - 20"					30
PCL3X40	PPL3X40	CL3X40	KL3X40	1 - 30"					35
PCL1X50	PPL1X50	CL1X50	KL1X50	1 - 10"	X50	1/15	465	3/4" hose barb	25
PCL2X50	PPL2X50	CL2X50	KL2X50	1 - 20"					30
PCL3X50	PPL3X50	CL3X50	KL3X50	1 - 30"					35
PCL1X100	PPL1X100	CL1X100	KL1X100	1 - 10"	X100	1/10	600	3/4" hose barb	25
PCL2X100	PPL2X100	CL2X100	KL2X100	1 - 20"					30
PCL3X100	PPL3X100	CL3X100	KL3X100	1 - 30"					35

¹ PVDF systems have NPT connections.

² Order filter media separately

³ Standard motors are 100-110V/1/50-60 with 6 ft. cord and 60 Hz plug. Optional 230V/1/50-60 motor available.

⁴ U.S. GPH @ 60 Hz, see flow curve.

ACCESSORIES

DESCRIPTION	ADD TO SYSTEM NO.
Viton elastomers on filter chamber and pump	-V
Optional motor 230V/1/50-60	-5

DESCRIPTION	PRICE CODE NO.	
	X40	X50 & X100
Hose Kit (Includes priming kit)	PVC & CPVC 99-1600	99-1602
	PP 99-1601	99-1603
Filter Media - order separately. Refer to Bulletin M-109 (cartridge and sleeves) or M-305 (carbon)		

CARBON PURIFICATION CHAMBER with flow control valve, hose & drain	PRICE CODE NO.	
	CPVC	PVC
Includes ABS mini-canister / CPVC or clear PVC chamber for 0.9 lbs. granular carbon 10" canister 2.1 lbs. granular carbon 20" canister 3.2 lbs. granular carbon 30" canister	O-C1CM O-C2CM O-C3CM	O-P1CM O-P2CM O-P3CM
Includes CPVC or clear PVC chamber for 1.2 lbs. granular carbon 2.5 lbs. granular carbon 3.8 lbs. granular carbon	O-C1C O-C2C O-C3C	O-P1C O-P2C O-P3C
Includes CPVC or clear PVC chamber for 0.6 lbs. 10" carbon cartridge 1.2 lbs. 20" carbon cartridge 1.8 lbs. 30" carbon cartridge	O-C1CC O-C2CC O-C3CC	O-P1CC O-P2CC O-P3CC



DIMENSIONS

SYSTEM NO.	A	B
1 X 40	3 3/4"	21 1/2"
2 X 40		31 1/2"
3 X 40		41 1/2"
4 X 40		51 1/2"
1 X 50	4"	21 1/2"
2 X 50		31 1/2"
3 X 50		41 1/2"
4 X 50		51 1/2"
1 X 100	4"	21 1/2"
2 X 100		31 1/2"
3 X 100		41 1/2"
4 X 100		51 1/2"

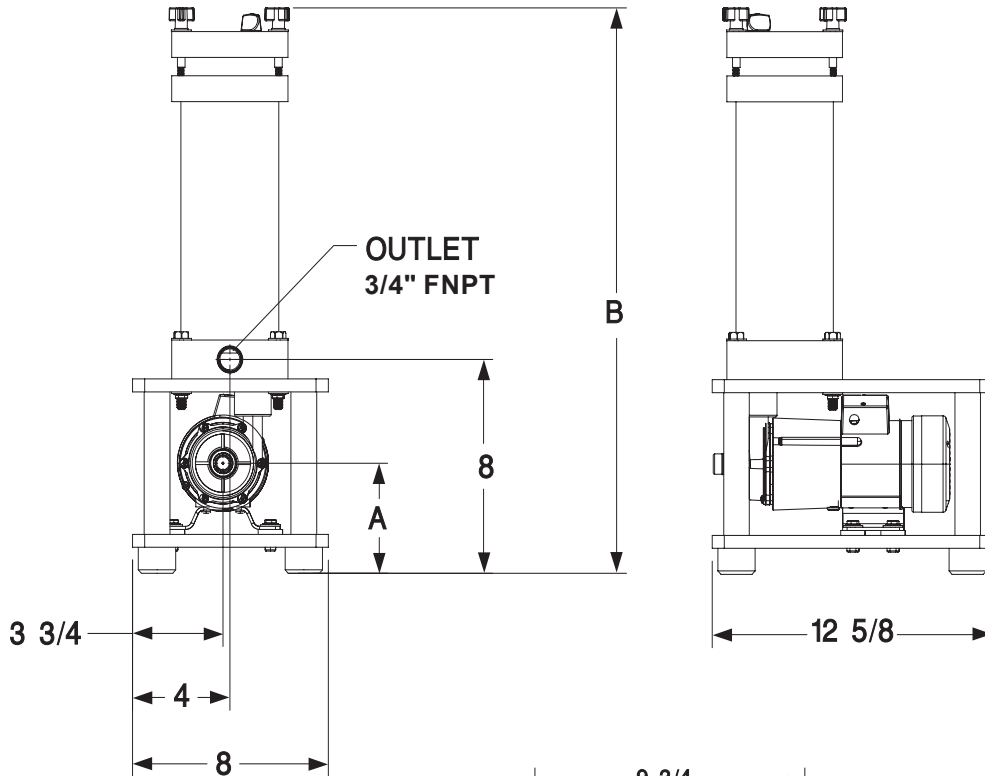

**LABMASTER 'LX'
FILTRATION SYSTEMS
with OPTIONAL CARBON
PURIFICATION CHAMBER**

