

# 1-1/2" - 2" AIR DRIVEN DIAPHRAGM PUMP

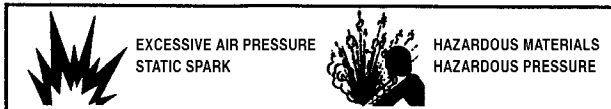

Refer to Bulletin P-605,  
Parts List P-9155, P-9181

## AIR DRIVEN, DOUBLE DIAPHRAGM PUMP MANUAL

Congratulations on purchasing one of the most durable and versatile pumps made anywhere. With the proper installation and maintenance the pump will provide years of great performance.

READ THESE WARNINGS AND SAFETY PRECAUTIONS PRIOR TO INSTALLATION OR OPERATION. FAILURE TO COMPLY WITH THESE INSTRUCTIONS COULD RESULT IN PERSONAL INJURY AND OR PROPERTY DAMAGE. RETAIN THESE INSTRUCTIONS FOR FUTURE REFERENCE.

**⚠WARNING** Before placing the pump in service make certain it is compatible with the fluid being pumped. Changes of temperature, concentrations or combinations of chemicals may vary resistance of material. Always consult Material Safety Data Sheets and Engineering Resistance Tables for chemical compatibility.

- Be certain all operators of this equipment have been trained for safe working practices.

**⚠DANGER HAZARDOUS MATERIAL:** Protective eye wear and clothing should be used whenever pumping hazardous or toxic fluids.

- If a diaphragm ruptures, the pumped product can enter the air side of the pump and exit through the air exhaust. When the fluid is hazardous pipe exhaust away from the work area and personnel.
- When the fluid source is at a higher level than the pump (flooded suction), the exhaust should be piped to a higher level than the fluid source to prevent spills caused by siphoning if a diaphragm rupture should occur.

**⚠DANGER HAZARDOUS PRESSURE:** Do not clean or service pump, hoses or dispensing valves when the system is pressurized - serious injury may result.

- Disconnect air supply line and relieve pressure from the system prior to disassembly.

**⚠DANGER STATIC WARNING:** Pumping of flammable materials may cause a build-up of a static charge within the electrically non conductive pumps. Static spark can cause explosion resulting in severe injury or death. Ground pump and pumping systems when pumping flammable products or when used in a location where surrounding atmosphere is conductive to spontaneous combustion. Optional conductive non-metallic models are available when grounding is necessary. Use grounding lugs and always connect to a good ground source.

- Secure pump, connections and all contact points to avoid

vibrations and generation of contact or static spark. Periodically verify continuity of electrical path to ground with an ohmmeter from each component.

- Consult local building codes and electrical codes for specific grounding requirements.
- Use hoses incorporating a static wire.
- Use proper ventilation
- Keep flammables away from heat, open flames and sparks.
- Keep containers closed when not in use.

**⚠WARNING** Maximum temperatures are based on mechanical stress only. Certain chemicals will significantly reduce maximum safe operating temperature. Consult engineering guides for chemical compatibility and temperature limits.

- Always use minimum air pressure when pumping at elevated temperatures.

**⚠WARNING** Excessive air pressure can cause pump damage, personal injury or property damage.

**⚠WARNING** Pump must be reassembled properly after maintenance.

**⚠CAUTION** Do not use the pump for the structural support of the piping system. Be certain the system components are supported to prevent stress on the pump parts.

- Flexible connections will avoid damage to piping due to vibration.

**⚠DANGER** = Immediate hazards which will result in severe personal injury or death.

**⚠WARNING** = Hazards or unsafe practices which could result in severe personal injury, death or substantial property damage.

**⚠CAUTION** = Hazards or unsafe practices which could result in minor personal injury, product or property damage.

## INSTALLATION

**NOTICE:** Re-torque fasteners prior to use. Refer to torque requirements listed in maintenance manual and attached to pump.

1. A lube-free, clean, dry, compressed air source (or any nonflammable, compressed gas) is recommended. Use a filter that is capable of filtering out particles larger than 50 microns.
2. All pumps should be mounted in an upright position with the exception of the 1/4" models which may be rotated 360° to suit the application.
3. When particles exceed the maximum particle specification of the pump or are sharp enough to cut elastomers install a particle fluid filter on the fluid suction line.
4. Fluid suction lines and air exhaust lines should never be smaller than specified pipe size of pump.
5. Apply PTFE tape to threads upon assembly to prevent leakage.
6. Never use pipe dope on air line connections.
7. Never use collapsible tube on fluid inlet.
8. Do not exceed 10 ft-pounds of torque on plastic pipe threads.
9. If changing to a different application reconfirm compatibility of fluid.

## SUBMERGED APPLICATIONS

1. Fluid must be compatible with fasteners and with intermediate material.
2. Pipe exhaust above the level of the fluid.

## HIGH VISCOSITY APPLICATIONS

1. Position the pump close to or below the level of the fluid source.
2. Suction lines should be increased in size - up to three times the size of the inlet manifold. Dual manifolds may be used when available.
3. Start the pump slowly using a valve on the air line.

## LOW TEMPERATURE and UV EXPOSURE

1. Polypropylene tends to embrittle at freezing temperature. Pump must be insulated or heated, otherwise use pumps with different materials of construction.
2. If excessive icing occurs at the pump exhaust, air source must be dried using mechanical means or through the introduction of ethyl alcohol in the air line.
3. UV rays will damage polypropylene pumps, either shroud the pumps from UV rays or use pumps with UV stabilized materials.

## GENERAL MAINTENANCE

1. Check periodically for product or air leakage. Tighten any joint where leakage is occurring.
2. When pumping hazardous or toxic materials, diaphragms should be replaced at regularly scheduled

intervals based upon pump usage.

3. In freezing temperatures, the pump must be completely drained when idle.
4. When pumping highly abrasive fluids reduce discharge flow rate or reduce air pressure to prolong diaphragm life.
5. If you are pumping a material that will settle or compact the pump must be flushed before shut down.

## TROUBLE SHOOTING

### ***Air is applied to pump but pump is not starting***

1. Clean filters and debris from all fluid lines
2. Make sure all valves on fluid lines are open.
3. Inspect diaphragms for rupture.
4. Air pressure must not be below 20 psi (1,3 bar)

### ***Pump is pumping but not priming***

1. Check all suction line connections for leakage.
2. Inspect check valves for wear or debris.
3. Suction lift specifications may be exceeded.
4. If fluid is viscous use larger suction lines.

### ***Leakage***

1. Retorque all fasteners to specified torque requirements.
2. Replace o-rings.
3. Inspect diaphragms for rupture

### ***Low flow rate***

1. Confirm air pressure and air capacity at the air valve as required.
2. Check for leaks in suction line or obstructions in lines.
3. If fluid is viscous use larger suction lines.
4. Viscosity of fluid may have increased if temperature is lower.

### ***Air in discharge lines***

1. Check for leaks in suction lines.
2. Inspect diaphragms for rupture.

### ***Erratic cycling***

1. Inspect check valve seats for debris.
2. Inspect fluid lines for debris.
3. Automatic valves must be properly functioning.
4. Viscosity of product may be changing.

### ***Premature destruction of wetted components***

1. If fluid is abrasive slow down pump or increase size of pump
2. Filter fluid for sharp objects.
3. Make sure fluid is compatible with wetted materials.

## 1-1/2", 2" PERFORMANCE PLUS MAINTENANCE MANUAL CHECK VALVE AND O-RING MAINTENANCE

1. Flush and neutralize the pump to be certain all corrosives or hazardous materials are removed prior to any maintenance. This procedure should always be followed when returning pumps for factory service also.
2. **PLASTIC PUMPS:** Remove the elbow to outer pumping chamber band clamps (35). Suction check valve seats (26) and check balls (27) are located inside of the bottom of the outer chamber (28). Gently remove and inspect for excessive wear, pitting or other signs of degradation. Inspect valve seat o-rings (24) and replace if necessary. Discharge check valves are located inside of the bottom of the discharge elbows (32). Repeat procedure for inspection of discharge check valves.
- 2A. **METAL PUMPS:** To inspect the check valves, remove the cap screws (19) from manifold sections (21, 23). Repeat procedure above. There are no manifold o-rings in the metallic pumps.
3. To inspect the manifold o-rings remove the manifold band clamps from each manifold assembly. Inspect and replace o-rings if necessary. Then reassemble, lightly tighten fasteners. The check ball should fit into the curved portion of the valve seat facing upward when reinserted into the valve seat location. Tighten all external fasteners to final torque requirement after pump is completely assembled.  
**NOTE: When using pumps built with PTFE o-rings always replace with new PTFE o-rings, since the original o-rings will not reseal the pump.**

### DIAPHRAGM AND PILOT SLEEVE ASSEMBLY MAINTENANCE

4. To inspect diaphragms remove cap screws (16) and reinforcement bracket (25) from the outer pumping chambers. If replacement is necessary due to abrasion or rupture unscrew the outer diaphragm plates (29). Models that are built with PTFE elastomers will have a PTFE overlay (30) that faces the outer pumping chamber (28) and a back-up diaphragm (31) on the air side of pump. Pumps without PTFE will contain only the back-up diaphragms.
5. If there has been a diaphragm rupture and corrosive or viscous fluid has entered the air side of pump the complete air system should be inspected. After removing diaphragms, inner diaphragm plate (33), and flat washer (47) the pilot sleeve assembly (13, 14, 15, 42, 45, 48) and diaphragm rod assembly (34, 49) may be removed by removing the retaining plates (46) (you may only need to remove one retaining plate) and pushing the entire unit out through the bore in the intermediate (41). Diaphragm rod assembly must be unscrewed to remove pilot sleeve.  
**NOTE: To aid in reassembly use a non-synthetic, petroleum based lubricating grease without EP additives. Carleton-Stuart MagnaLube G is recommended.**
6. Clean or replace any components that have excessive wear, dirt build-up, or chemical attack. Lube all components prior to reassembling. Reassemble pilot sleeve spacers, o-rings and lip seals (14) within bore of intermediate. Make sure that the open side of the lip seals is facing outward toward the diaphragms. Also make sure that the end pilot spacers (45) are at the end on either side of the pilot sleeve assembly and all inner spacers (48) are separated by o-rings. Next carefully insert the diaphragm rod assembly with pilot sleeve assembly inside the bore. Reattach retaining plates. Do not over tighten self-tapping screws (38).
7. With the curved side of the inner diaphragm plate facing the diaphragm, assemble onto outer diaphragm plate stud and then screw assembly into diaphragm rod. Push diaphragm rod to opposite side of intermediate and add the opposite diaphragm assembly. **Tighten the outer diaphragm plates to 372 in-lbs (42,04 NM) of torque.** Assemble the outer chamber, reinforcement brackets and bolts first on the side where the diaphragm has been inverted. Next reach under

the opposite diaphragm assembly and pull diaphragm rod to opposite side (a large flat screwdriver may be used as an aid in this process) and assemble remaining outer chamber, reinforcement brackets and cap screws. When positioning outer diaphragm chambers onto intermediate make sure that witness lines are matching.

**NOTE: If air valve has been removed, proper orientation of air system with fluid chambers must be observed. The top of the intermediate has a single vertical air passage slot on the air valve mounting face while the outer chamber check ball cavity should be pointing downward.**

- PLASTIC PUMPS NOTE:** When positioning band clamps use soapy water or a compatible lubricating spray on the inside of band clamps to aid assembly. Tap with a mallet on the outside of clamp to help position the clamp while tightening the fasteners. The band clamp fasteners and cap screws are stainless steel. To prevent galling always apply an anti-seize compound to the thread. Tighten all external fasteners to final torque requirement after pump is completely assembled.
8. Position the reassembled manifolds making sure of the proper orientation in relation to the air valve for your application. Also make sure that the valve seat o-rings do not shift from their grooves during reassembly. Flat washers should be placed under the head of each cap screw and nut. Tighten all external fasteners to final torque requirement after pump is completely assembled.
  - 8A. **METAL PUMPS:** Position manifold/elbow sections making sure that the valve seat o-rings do not shift from their grooves. Tighten fasteners on bolts loosely.

### EXTERNAL FASTENER TORQUE REQUIREMENTS

**NOTE: When reassembling loosely tighten all external fasteners adjusting and aligning and gradually, in an alternating fashion, tighten to torque requirements listed below.**

CHAMBER BOLTS (Outer Chamber – all versions),

15 ft-lbs (20,34 NM)

BAND CLAMPS (Manifolds and Elbow), 80 in-lbs (9,04 NM)

METAL PUMPS (Elbow to Chamber Bolts), 37 ft-lbs (50,17 NM)

AIR VALVE CAP SCREWS, 40 in-lbs (4,52 NM)

### AIR VALVE MAINTENANCE

9. To evaluate air valve components, remove the six cap screws (11), washers, (8, 10) and nuts from the air valve body (7). The valve plate (5) and shuttle (6) may be inspected by removing them from their location in the slot in the back of the air valve. Inspect for scratches or surface irregularities. Replace if necessary. To remove the plug (1) at the bottom of the air valve, point the bottom of the air valve safely away from people, direct compressed air through one of the lower holes in the back of the air valve body and the plug will shoot out. Next push the air valve spool (2) out of the air valve body. Gently reach in and pull lip seals (43) out of inside bore of the air valve body. Check for cracks, splitting or scratches. Clean components if replacement is not necessary. Inspect plug o-ring (44) for any damage and replace if necessary and reinsert in o-ring groove.  
**NOTE: Make sure that the open side of the two lip seals face each other when reassembling air valve. Lube all components with suggested maintenance grease as an aid in reassembly.**
10. Reinsert air valve spool inside of air valve body. Place shuttle on middle rib of air valve spool through the square slot in back of air valve. If using original valve plate lubricate side of plate that was facing the shuttle (or if new valve plate is used lubricate the lapped and polished side of plate) and place the lubricated side next to the shuttle in the slot. Press valve plug into air valve body, chamfered end first.
11. Check that gasket (4) is not cracked and if damaged, replace.
12. After gasket is pressed back into position, align air valve onto intermediate and reinsert the six cap screws with lock washer and flat washers. **Apply 40 in-lbs (4,52 NM) of torque to fasteners.**

## SPECIFICATIONS: 1-1/2", 2" PERFORMANCE PLUS

### 1-1/2" CAPACITY:

Adjustable 0-130 GPM (492 LPM)

### 2" CAPACITY:

Adjustable 0-180 GPM (681 LPM)

### MAXIMUM TEMP:

PVDF models – 200°F (93°C)  
Other plastic models – 150°F (66°C)  
Metallic models – 200°F (93°C)

### MAXIMUM AIR PRESSURE:

120 psi (8,2 bar)

### MINIMUM AIR PRESSURE:

20 psi (1,3 bar)

### WEIGHT 1-1/2" Models:

Poly models – 46lbs (20,8 kg)  
PVDF models – 65lbs (29,4 kg)  
Alum models – 60lbs (27,2 kg)  
SS models – 133lbs (60,3 kg)

### WEIGHT 2" Models:

Poly models – 48lbs (21,7 kg)  
PVDF models – 69lbs (31,3 kg)  
Alum models – 61lbs (27,7 kg)  
SS models – 133lbs (60,3 kg)

### DRY LIFT:

Models with PTFE balls – 10 feet (3 meters)  
Other models – 15 feet (4,5 meters)

### MAXIMUM SOLIDS:

1/4" (6,4 mm)

### AIR SUPPLY:

Inlet – 3/4" NPT Female (BSP compatible)  
Outlet – 3/4" NPT Female

### FLUID INLET/DISCHARGE:

1-1/2" Flange (ANSI and DIN compatible)  
2" BSP Female (2" metal models)  
2" Flange (2" plastic models)  
(ANSI and DIN compatible)

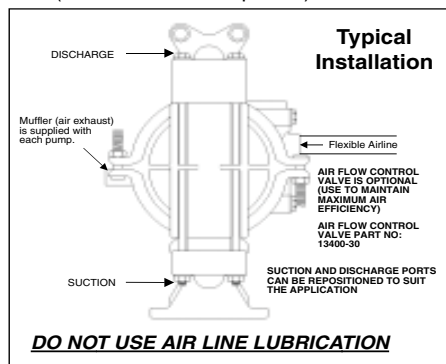

## 2" PERFORMANCE CURVE

(Based on water-flooded suction)

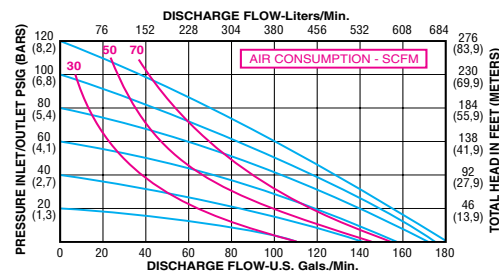

## 1-1/2" PERFORMANCE CURVE

(Based on water-flooded suction)

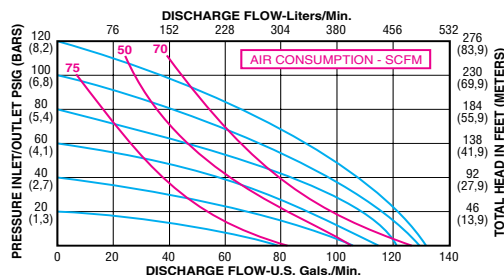

## 1-1/2" DIMENSIONS Dimensions in inches and (mm)

### Plastic

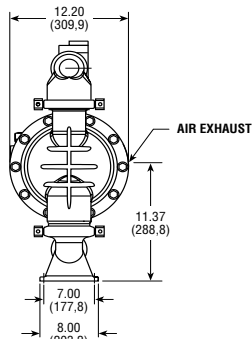
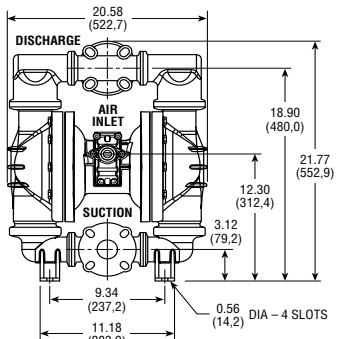

### Metallic

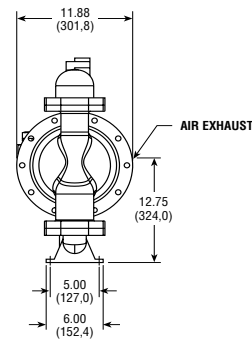
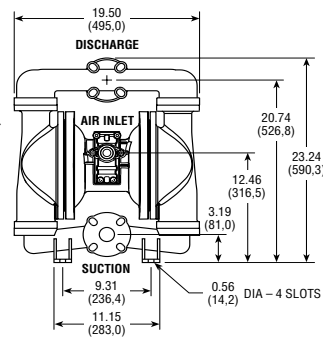

## 2" DIMENSIONS Dimensions in inches and (mm)

### Plastic

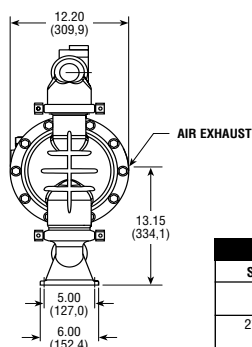
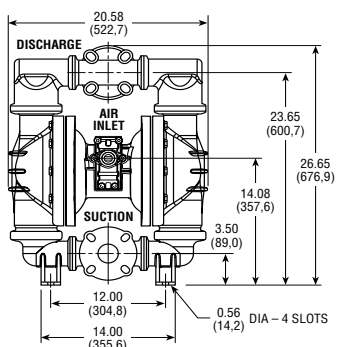

### Metallic

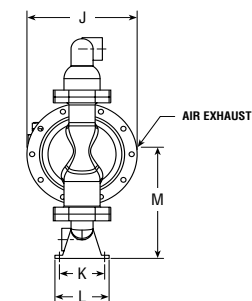
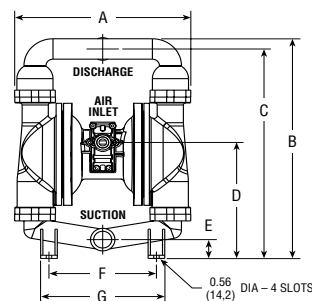

MODEL	DIMENSIONS Inches / (mm)											
	Size (Inlet/Outlet)	A	B	C	D	E	F	G	J	K	L	M
2" Aluminum NPT & BSP	19.50 (495.0)	26.26 (667.0)	25.04 (636.0)	13.86 (352.0)	2.25 (57.1)	10.06 (255.5)	12.00 (304.8)	12.20 (309.9)	12.20 (127.0)	5.00 (127.0)	6.00 (152.4)	12.90 (327.6)
2" Stainless Steel NPT & BSP	19.50 (495.0)	24.62 (625.3)	23.00 (584.2)	15.05 (382.3)	3.50 (89.0)	12.00 (304.8)	13.85 (351.5)	12.20 (309.9)	12.20 (127.0)	5.00 (127.0)	6.00 (152.4)	14.10 (358.1)
Flanged 2" Flange	19.50 (495.0)	24.62 (625.3)	21.62 (549.2)	13.25 (336.6)	3.50 (89.0)	12.00 (304.8)	13.85 (351.5)	11.88 (301.8)	12.20 (127.0)	5.00 (127.0)	6.00 (152.4)	12.75 (324.0)

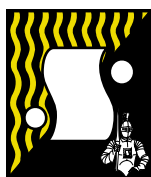

# SERFILCO, LTD.

2900 MacArthur Blvd. 847-509-2900  
Northbrook, IL 60062-2005 U.S.A. 800-323-5431  
e-mail: sales@serfilco.com FAX: 847-559-1995  
www.serfilco.com