



SERIES 'HB' VERTICAL PUMPS

Built 12-1-87 & after

(For pumps built prior to 12-1-87 see page 4)

OPERATION AND
SERVICE GUIDE
O-891B
JULY 1992

SAFETY PRECAUTIONS BEFORE STARTING PUMP

1. Read operating instructions and instructions supplied with chemicals to be used.
2. Refer to Chemical Resistance Data Chart for compatibility of materials in pump with solution to be used.
3. Note temperature and pressure limitations.
4. Personnel operating pump should always wear suitable protective clothing; face mask or goggles, apron and gloves.
5. All piping must be supported and aligned independently of the pump.
6. Always close valves slowly to avoid hydraulic shock.
7. Ensure that all fittings and connections are properly tightened.

BEFORE CHANGING APPLICATION OR PERFORMING MAINTENANCE

1. Wear protective clothing as described in item 4 above.
2. Flush pump thoroughly with a neutralizing solution to prevent possible harm to personnel.
3. Verify compatibility of materials as stated in item 2 above.
4. Shut off power to motor at disconnect switch.

IMPORTANT

1. The pump is constructed entirely of CPVC with fasteners of Titanium or Hastelloy C® (optional). Pump shaft is made from stainless steel and protected by a CPVC sleeve. Although CPVC may be chemically compatible with the solution being pumped, care should be taken to protect the pump components against unnecessary wear and physical abuse.
2. Record all model and serial numbers for future reference. Always specify model number and serial number when ordering parts.
3. Pump flow curves are based upon pumping water. Increased motor horsepower may be necessary for pumping other liquids or reduced motor horsepower may be permissible when pumping at higher discharge head. Refer to pump curve.
4. Impellers are designed to offer maximum pump output and the motors are sized for non-overloading at maximum flow conditions. Impellers may be trimmed to reduce flow and discharge head, if desired. See parts list for impellers of various diameters.
5. Vertical discharge piping from the pump should be supported so that the pump does not take the forces generated by the weight of the pipe and the liquid being pumped.
6. Plastic piping has a high thermal expansion and should be considered when attaching discharge piping. Refer to Bulletin A-207 for pipe, pipe fittings, etc.
7. Motor has been tested and is WIRED FOR LOW VOLTAGE OPERATION, 115 VOLTS SINGLE PHASE OR 230 VOLTS THREE PHASE. Motor leads must be changed if motor is to be operated at 230 volts, single phase or 460 volts, three phase. See motor decal.

Refer to Bulletin P-302 Parts List P-8950

8. Pumps are equipped with FRESH WATER FLUSH LINES TO RINGS AND LINER FOR LUBRICATION. If fresh water is unavailable or unacceptable to solution or system, the fresh water flush line can be converted to solution flush line. Refer to section "J" for conversion instructions. NOTE: Flush pressure to be 15 PSI minimum at flush manifold.

PRE-START-UP

1. Verify that operating temperature is not in excess of pump design temperature of 165°F maximum for single bearing and 140°F multiple bearing. Rulon® bearings are not for temperatures above 140°F.
2. Connect electrical supply to motor starter. If starter is furnished, verify that starter and motor are wired for the correct operating voltage and correct overload heaters. It is recommended that a motor starter be installed, if one was not provided with the pump assembly, for overload protection.
3. Secure pump to edge of tank or sump and complete discharge piping.
4. Wire motor for clockwise rotation when looking down on fan end of motor. If pump rotation is incorrect, turn off power and interchange any two POWER SOURCE WIRES. DO NOT RUN PUMP WITHOUT BEARING FLUSH.
5. All units are factory tested to meet published or specified flow rates and to confirm that the pump and motor functioned properly at time of shipment.
6. With pump running, listen for any unusual noise, vibration or other abnormal condition which could influence pump performance. Suction casing must be flooded for pumping action to start.
7. Check correct operation of level control. Make necessary adjustments for establishing high level and low level.
8. At MAXIMUM flow conditions, measure amperage on all lines. If in excess of motor nameplate ratings, stop pump and consult factory.
9. Pump suction casing includes a suction strainer to protect the pump impeller from damage where debris may be present. A modification to your sump should be employed to adequately screen excessive debris. The drawing illustrates a possible method of providing for extended surface area, easily cleaned without interruption to the pump.

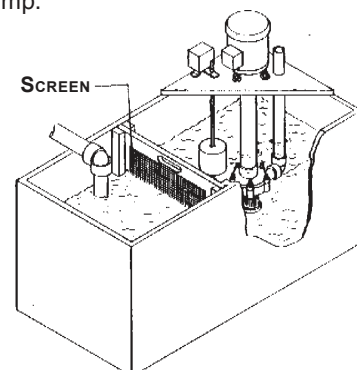

- The most desirable bearing lubricant is a clean liquid (less than 10 micron particle size) that has good lubricating qualities. Alternate methods of lubrication should not be considered whenever this method is available. Filter chamber with 10 micron cartridge is available for bearing lubricant. Price Code Number 99-0159.

PUMP SERVICE

A. TO REPLACE SUCTION CASING AND "O"-RING

-  Turn off power. Disconnect electrical lines from motor and remove pump from tank or sump. Drain all liquid from pump. Pump should be placed with the motor fan cover on the floor and the pump column up in a vertical position and the suction casing at the top.
- Remove the six cap nuts and cap nut studs holding the suction casing to the support casing and column. 'O'-ring can be removed from groove in support casing. 'O'-rings in cap nuts and cap nut studs should be replaced also.
- Lubricate 'EPDM' 'O'-rings with water or glycerol only and Viton with glycerol or grease.
- Position suction casing to duplicate original discharge position.
- Replace suction casing and tighten cap nuts until they just bottom on suction casing. Tighten in an alternating pattern. If cap nuts are over tightened they may crack.

B. TO REPLACE IMPELLER OR SHAFT SLEEVE

- Follow steps A1 and A2. Hold shaft with vise grips between motor and pump. Shaft sleeve and impeller will unscrew from pump shaft via turning counterclockwise. Pull shaft sleeve and impeller from pump shaft.
- Remove the impeller by holding the shaft sleeve and turning impeller clockwise. Use strap wrench. Note, this is a left hand thread.
- Replace the shaft sleeve assembly by pushing rings into liner and screwing impeller counterclockwise onto pump shaft. Replace suction casing (Steps A3 to A5)

C. TO REPLACE LOWER CERAMIC LINER

- Remove the suction casing as outlined in Section "A" and impeller and sleeve assembly as outlined in Section "B".
- With vise grip pliers hold pump shaft securely at motor. Use a strap wrench over impeller and turn counterclockwise to loosen.
- Remove the two hex screws, 1/4" nipple and locking nuts from side of column. Unscrew support casing, liner can be lifted out of pump column. Replace liner making sure center hole in liner is aligned with flush hole in column. Reassemble pump. Screws holding liner in place must not penetrate beyond inside wall of liner. Lock screws with jam nut against the column

D. TO REPLACE UPPER CERAMIC LINER

- Follow procedure as outlined in Section "A" and "B".
- Remove hex screw and 1/4" nipple at the column coupling. Remove lower column which is attached to support casing by using chain pipe wrench on each section of column. Turn lower section only. Liner in upper section is removed by taking out the two hex screws and locknuts holding the liner in place. If your pump has three liners, use the same procedure for removing the additional liners.
- Replace and reassemble in reverse order. Be sure that shaft is concentric with lower liner before replacing shaft

sleeve. Screws holding liner in place must not penetrate beyond inside wall of liner.

E. TO REPLACE ROTATING RINGS (SINGLE BEARING)

- Remove suction casing, shaft sleeve and impeller as outlined previously.
- Unscrew impeller-coupling assembly clockwise from sleeve. NOTE, this is a left hand thread.
- Slide lower rings off key way on sleeve and replace with new rings. See Figure 1 for ring orientation.
- Re-assemble with spacer between rings and follow step D3.

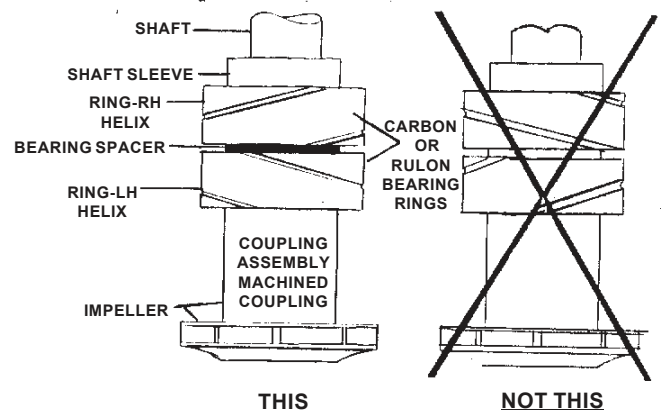
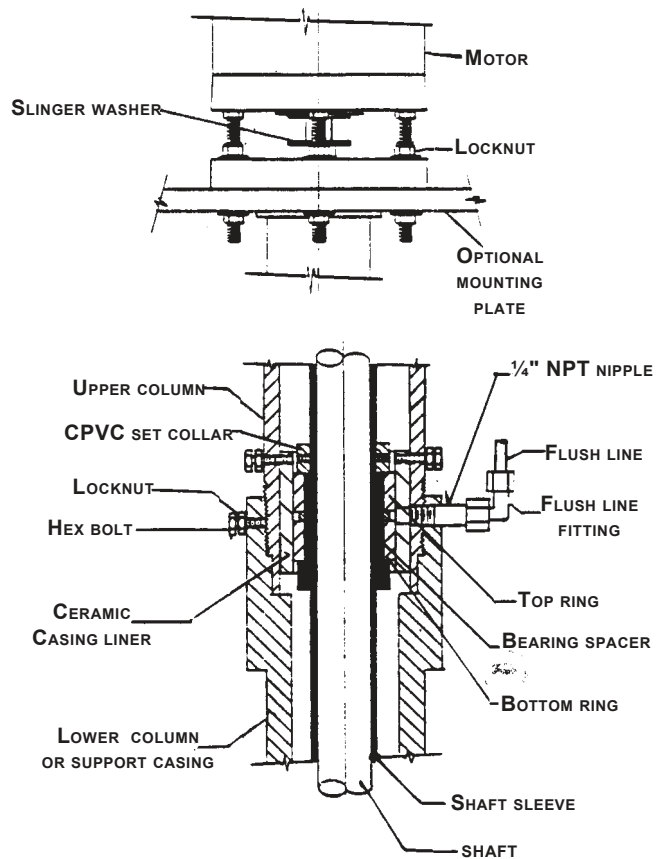

THIS **NOT THIS**
FIGURE 1 BEARING RING ASSEMBLY

F. TO REPLACE RING (MULTIPLE BEARING)

1. Remove suction casing, shaft sleeve and impeller as outlined above, unscrew impeller in a counterclockwise rotation from sleeve.
2. Slide lower rings off key way on sleeve and replace with new rings. See Figure 1 for ring orientation.
3. At top end of sleeve, loosen set screws in collar and remove. Rings can be slid off key in retainer and replaced with new rings.
4. If pump is a three bearing model remove top collar, top ring retainer and top collar from middle bearing. Replace parts in reverse order.
5. Replace the shaft sleeve impeller assembly by pushing bearing rings into ceramic liner and screwing impeller onto pump shaft clockwise. Replace suction casing (Steps A3 to A5).

G. TO REPLACE PUMP COLUMN (SINGLE BEARING)

1. Follow Steps A1, A2, B2, D2 to remove suction casing, impeller and shaft sleeve.
2. Remove flush line, mounting plate, and the four hex head nuts holding column to motor studs. After column is removed do not tamper with lock nut on stud.
3. Check for shaft tip concentricity by hand rotating shaft and gauging tip for eccentric rotation. Use a dial indicator to check shaft run-out. If eccentricity is greater than .005, shaft should be straightened. Turn pump over so that motor rests on its feet. Push down on the tip of the shaft at the point of maximum runout. Repeat this operation until shaft is within .005 T.I.R.
4. Replace pump column and hold with hex nut and washers. Note mounting plate orientation.
5. Check concentricity of pump shaft tip to I.D. of ceramic liner. Adjust by loosening and adjusting hex nuts at each side of column top flange. Concentricity to within .005 T.I.R.
6. Tighten all lock nuts, re-assemble sleeve, impeller and suction casing.

H. TO REPLACE PUMP SHAFT

1. Remove suction casing, impeller shaft, sleeve and column, follow instructions G1 and G2.
2. Remove motor fan cover and fan. Hold motor shaft with vise grips to prevent turning and remove pump shaft by gripping with vise grips and turning counter clockwise.
3. Use Loctite or equivalent on the threads of new shaft.
4. Straighten pump shaft as described in G3.
5. Assemble column and shaft sleeve. Check concentricity as described in G5 and G6.

J. FLUSH LINE CONVERSION

(From water flush to product flush)

1. Remove ¼"NPT plug from discharge pipe.
2. Use ¼" tube provided to connect ¼"NPT hole in discharge to ¼"NPT flush manifold inlet.

NOTES:

1. Pressure in discharge pipe at mounting plate must be 15 PSI minimum for adequate flush.
2. For solutions that will crystallize at lower temperatures, remove nipples, elbow and coupling leading to flush manifold. Drill 7/16" diameter and tap ¼"NPT into discharge pipe below mounting plate. Connect this hole to flush manifold ¼"NPT inlet beneath mounting plate. Plug 7/8" diameter hole in mounting plate.
3. Solution flush is not recommended when containing dirt or grit.

K. REPLACEMENT OF FLUSH LINE FILTER CARTRIDGE (optional)

1. Turn off pump.
 2. Turn off flush water supply.
 3. Remove cover of filter chamber.
 4. Replace filter cartridge with a 10 micron polypropylene cartridge.
 5. Replace filter chamber cover.
 6. Turn on flush water supply.
 7. Restart pump.
- NOTE: Failure to change filter cartridges on a regular schedule may result in insufficient flush line flow and subsequent bearing failure.

PUMPING TIPS

1. To reduce flow rate or discharge head, the impeller may be trimmed or a control valve installed in pump discharge.
2. When discharging overhead when there may be a considerable volume of liquid in the piping, it is recommended to install a check valve in pump discharge. This will prevent unnecessary back siphoning which could cause cycling of automatic level controls.
3. Pumps provided with suction extensions must **NEVER** be started without liquid above the impeller. Verify proper operation of level controls.
4. Review parts list and maintain an inventory of recommended spare parts for emergency replacement. This will assure that the pump is returned to operation with minimum delay.
5. Fan cooled motors require air movement for cooling. They should not be used when airborne dirt will have detrimental effect upon the solution being pumped.
6. Motor horsepower, as provided by the factory, is based upon pumping water (S.G. 1), unless otherwise specified. If field conditions cause a change in discharge head or solution density, CHECK MOTOR AMPERAGE during period of maximum flow rate. If amperage is in excess of motor name plate rating, stop pump and contact factory.
7. Periodically check suction strainer at bottom of pump. Remove all debris.
8. Flush pump after use if the solution crystallizes during downtime.
9. Whenever electrical leads are disconnected and replaced, verify correct rotation.

PREVENTIVE MAINTENANCE

Pumps should be removed from service periodically to inspect parts and perform maintenance. The time interval depends on length of time pump has been in service, solution being pumped and amount of abrasives in solution.

1. Clean debris that may be clogging suction strainer or suction extension.
2. Check wear of graphite or Rulon rings. Clearances greater than 1/8" on the ring diameter would require replacement.
3. Check flush line to rings and clean tubing.
4. Check concentricity of shaft and liner.

Pump is shipped with flush line for external water flush to bearings. For product flush (pumped solution) refer to "K" above.

If pump is furnished without discharge pipe, then connect manifold inlet to pump body (plug provided) or drill and tap a connection in site- installed discharge piping.

A clean external water source is our recommendation for lubricating the bearings. When pumped solution is used for bearing lubrication there is always the possibility of solids plugging the flush line with subsequent pump failure soon to follow. We then recommend our Series "L" filter chambers for installation in the flush line. Replace the filter cartridge before solution flow is restricted. Refer to pump service instruction "K".

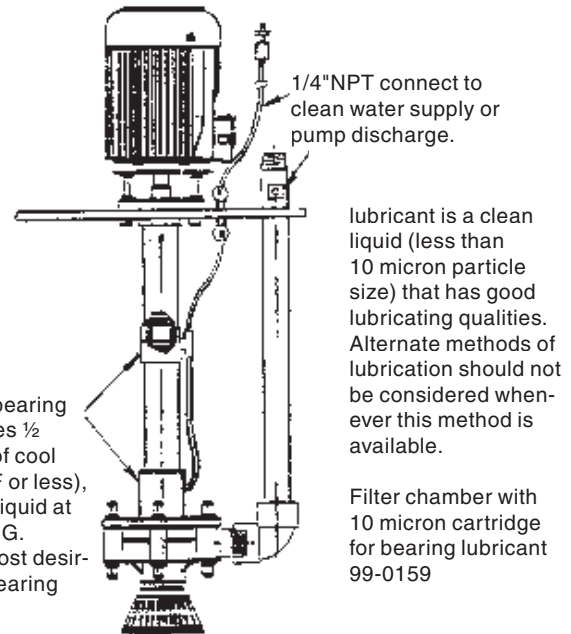

SERIES 'HB' VERTICAL PUMPS

Built prior to 12-1-87

NOTE

Instructions for pumps built prior to 12-1-87 are same as O-891 except for the following:

Refer to Parts List
P-8900 & P-9000

PUMP SERVICE

C. TO REPLACE LOWER CERAMIC LINER

1. Remove suction casing as outlined in Section "A" and impeller as outlined in Section "B".
2. With vise grip pliers hold pump shaft securely at motor. Use a strap wrench over impeller blades and turn clockwise.
3. Remove the two hex screws, 1/4" nipple and locking nuts from side of column. Unscrew support casing, liner can be lifted out of pump column. Replace liner making sure hole in liner is aligned with flush hole in column. Reassemble pump. Screws holding liner in place must not penetrate beyond inside wall on liner.

D. TO REPLACE UPPER CERAMIC LINER

1. Follow procedure as outlined in Section "A" and "B".
2. Remove set screw and 1/4" nipple at the column coupling. Remove lower column which is attached to support casing by using chain pipe wrench on each section of column. Turn lower section only. Liner in upper section is removed by taking out the two hex screws and locknuts holding the liner in place. If your pump has three liners, use the same procedure for removing the additional liners.
3. Replace and reassemble in reverse order. Be sure that shaft is concentric with lower liner before replacing shaft sleeve. Screws holding liner in place must not penetrate beyond inside wall of liner.

E. TO REPLACE RINGS (SINGLE BEARING)

1. Remove suction casing, shaft sleeve and impeller as outlined previously.
2. Slide lower rings off key way on sleeve and replace with new rings. See Figure 1 for ring orientation*.
3. Re-assemble sleeve and follow step D3.

F. TO REPLACE RINGS (MULTIPLE BEARING)

1. Remove suction casing, shaft sleeve and impeller as outlined above.
2. Slide lower rings off key way on sleeve and replace with new rings. See Figure 1 for ring orientation*.
3. At top end of sleeve, loosen set screws in collar and remove. Rings can be slid off key in retainer and replaced with new rings.
4. If pump is a three bearing model remove top collar, top ring retainer and top collar from middle bearing. Replace parts in reverse order.
5. Replace the shaft sleeve by pushing rings into ceramic liner and screwing impeller onto pump shaft. Replace suction casing (Steps A3 to A5).

* Replacement bearing rings are new helix groove design.

