



© 2021 SERFILCO Ltd, All Right

**SERFILCO**<sup>®</sup>

**Space-Saver 'SX', 'SM and 'SME' | System**

2900 MacArthur Blvd. Northbrook, IL. USA 60062 WWW.SERFILCO.COM (800) 323-5431

Parts List  
P-0776 - Page 1  
05/13/21

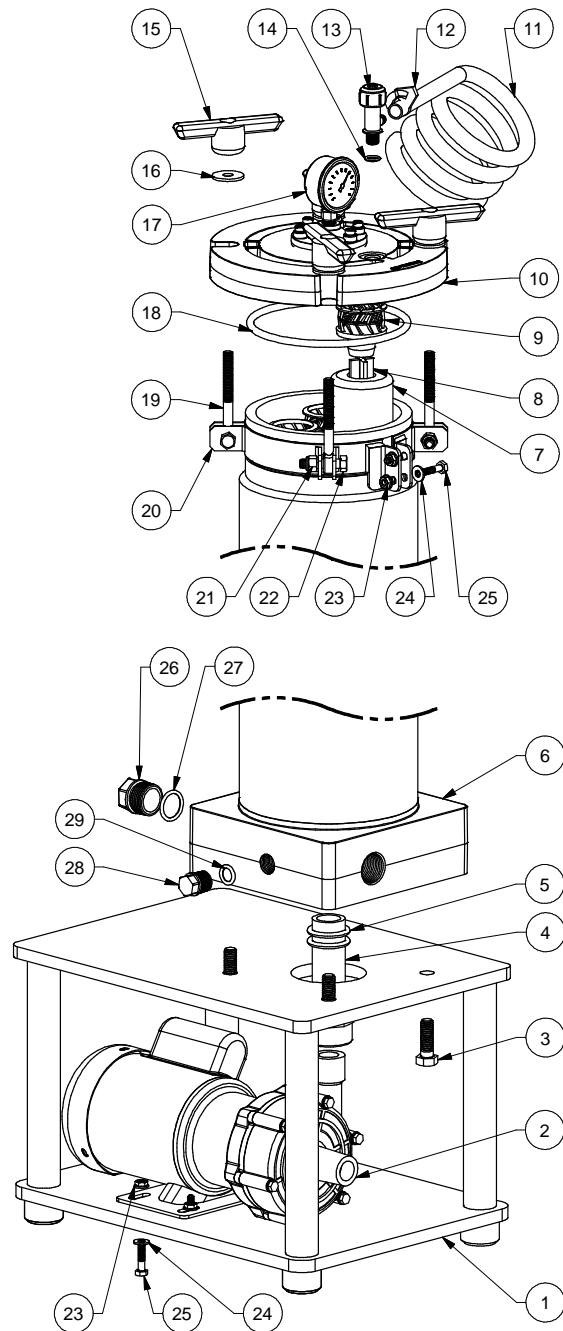

Item	Description	Qty	CS (CPVC)	PPS (PP)	KS (PVDF)
1	Stand 'SX' & 'SME4' 'SM' 'SME' 'SMES'	1		88-3456 88-3545 88-3545-5 88-3545-4	
2	Pump Series (see parts lists) 'X' 'M' 'ME4' 'ME' 'MES'	1		<b>P-9880</b> <b>P-4080</b> <b>P-5270</b> <b>P-5260</b> <b>P-5220</b>	
3	Bolt, 1/2"-13	4			11-0588
4	Pump Adapter SX, SM, SME 1NPT SM, SME 3/4NPT SME4 3/4NPT	1	88-3462-1 88-3544-C 88-3544-2C	88-3462-1PP 88-3544-PP 88-3544-2PP	88-3462-1K 88-3544-K 88-3544-2K
4A	Bushing, 3/4x1/2 (ME4 Only)	1	33-1131	33-1131-PP	33-1131-K
5	O-ring FKM EPDM	2		22-0905-V 22-0905	
6	Shell & base assembly 10" 20" 30" 40" 50"	1	88-3459-1C 88-3459-2C 88-3459-3C 88-3459-4C 88-3459-5C	88-3459-1PP 88-3459-2PP 88-3459-3PP 88-3459-4PP 88-3459-5PP	88-3459-1K 88-3459-2K 88-3459-3K 88-3459-4K 88-3459-5K
7	Filtration Media (See Bulletin)			<b>M-109</b>	
8	Tube guide 10" Cross post 20" 30" 40" 50"	3		88-0411 88-0350-4PP 88-0351-4PP 88-0352-4PP 88-0353-4PP	88-1611-K 88-1612-K 88-1613-K 88-1614-K 88-1615-K
	Cartridge spacer (not shown) FKM EPDM			22-0204 22-0218	
9	Hold down spring / cap	3		77-0844	77-1591-K
10	Cover	1	88-0387	88-2785	88-1339
11	Vent valve hose	8	PVC	22-0913	n/a
12	Hose clamp	1		22-0912	n/a
13	Vent valve	1	PP	33-8108-PP	33-2100
14	Vent valve / plug O-ring	1	FKM EPDM	22-0870-V 22-0870	-
15	Tee handle 3/8"	4		11-0265	
16	Flat washer 3/8" SS	4		11-0447	
17	Gauge guard G-3	1		99-0732	
18	Cover O-ring FKM EPDM	1		22-0940-V 22-0940	22-0565 22-0199
19	Swing bolt SS	4		11-0497-1	
20	Cover bracket SS	1		88-0596	
21	Nut 3/8" SS	4		11-0519	
22	Bolt 3/8"-16 SS	4		11-0444-1	
23	Nyloc nut 1/4"-20 SS	6		11-2191	
24	Flat washer 1/4" SS	12		11-0121	
25	Bolt 1/4"-20 SS	6		11-0390	
26	Plug 1NPT	2	33-0212	33-0212-PP	33-0212-K
27	O-ring FKM EPDM	2		22-0604 22-0605	
28	Plug, drain, 1/2 NPT	1	33-0866	33-0866-PP	33-0866-K
29	Drain plug O-ring FKM EPDM	1		22-2209-V 22-2209	

**The following items are not shown.**

Complete Chamber, pump adapter (item 4) not included					
10"		78-0361-C	78-0361-PP	78-0361-K	
20"		78-0362-C	78-0362-PP	78-0362-K	
30"		78-0363-C	78-0363-PP	78-0363-K	
40"		78-0364-C	78-0364-PP	78-0364-K	
50"		78-0365-C	78-0365-PP	78-0365-K	
Add 'V' to suffix of P/N for FKM O-rings					
Cover Support plate	SS	1	-	-	88-0597-1

Space-Saver 'SME' Product Bulletin:	<b>F-219</b>
Space-Saver 'SX' Product Bulletin:	<b>F-213</b>
Space-Saver 'SM' Product Bulletin:	<b>F-214</b>
Operation and Service Guide:	<b>O-0884</b>